

PL 2550

2x20kg
44 lbs

12

≥18mm EP
≥3/4"

≤500mm
≤19" 11/16

Peso máx. puerta
Peso max. porta
Max. Door weight

Dos puertas
Duas portas
Two doors

Espesor Madera
Espessura Madeira
Wood Thickness

Ancho Madera
Largura Madeira
Wood width

23
27

Riel PL 2550
Triho PL 2550
Carrier Track PL 2550

≥43mm

COMPONENTES / COMPONENTES / COMPONENTS

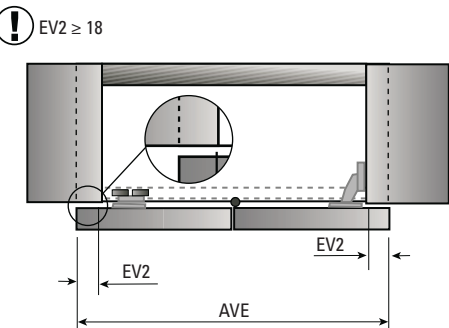
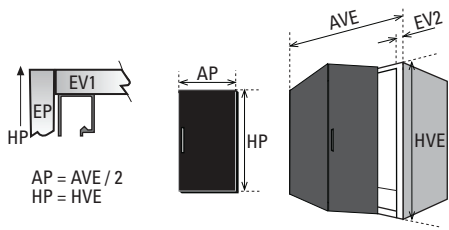
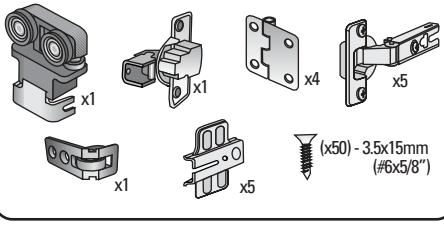

Todas las medidas expresadas en milímetros

Todas as medidas estão em milímetros.

All measurements in millimeters.

| mm | Decimal | Aprox Fraction | mm | Decimal | Aprox Fraction |
|----|---------|----------------|----|---------|----------------|
| 1 | 0.0394 | 3/64 | 6 | 0.2362 | 15/64 |
| 2 | 0.0787 | 5/64 | 7 | 0.2756 | 9/32 |
| 3 | 0.1181 | 1/8 | 8 | 0.3150 | 5/16 |
| 4 | 0.1575 | 5/32 | 9 | 0.3543 | 23/64 |
| 5 | 0.1969 | 13/64 | 10 | 0.3937 | 25/64 |

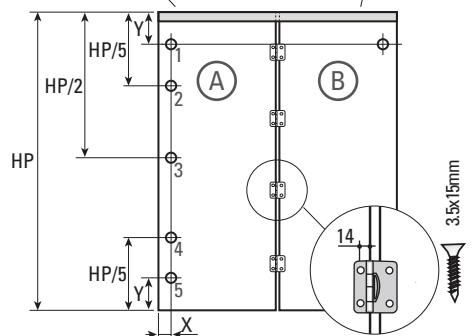
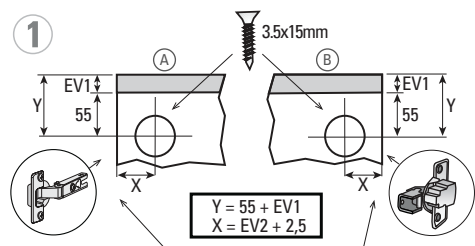
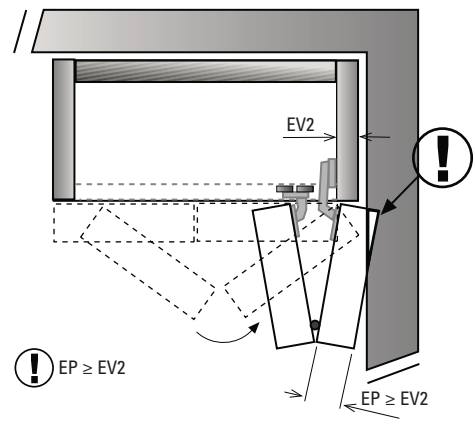

| | HP < 900 | x2 | 1 y 5 |
|-----|-----------------|----|----------------|
| (A) | HP = 900 - 1600 | x3 | 1, 3 y 5 |
| | HP > 1600 | x5 | 1, 2, 3, 4 y 5 |

ø35
ø1" 3/8

