

# DN80 CF

Madera / Madeira / Wood

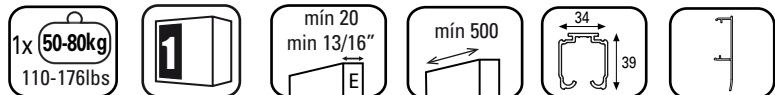

1x (50-80kg) 110-176lbs  
 Una puerta / Uma porta / One door  
 Espesor Madera / Espessura Madeira / Wood Thickness  
 Ancho mínimo / Largura mínima / Minimum width  
 Riel U21 / Trilho U21 / Track U21 ST  
 Cenefa 66x8 / Sanefa 66x8 / Fascia U21

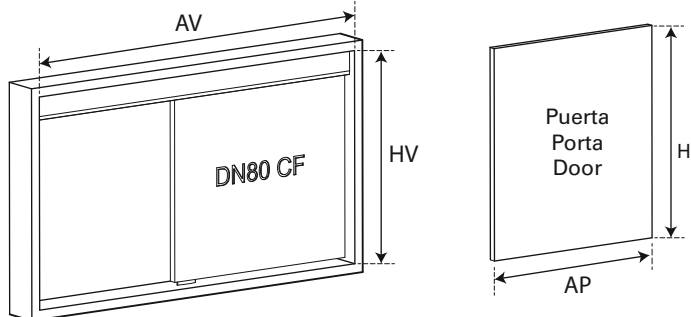

**DN80 CF**

- Roller (x2)
- Bracket (x2)
- Screw (x2)
- Washer (x2)
- Bracket (x1)
- Bracket (x2)
- Screw (x2)
- Screw A (x8) - #8x1"
- Screw B (x2) - #6x1"

Tools: Screwdriver, Drill (Ø3.0), Wrench (N°13), Cable ties.

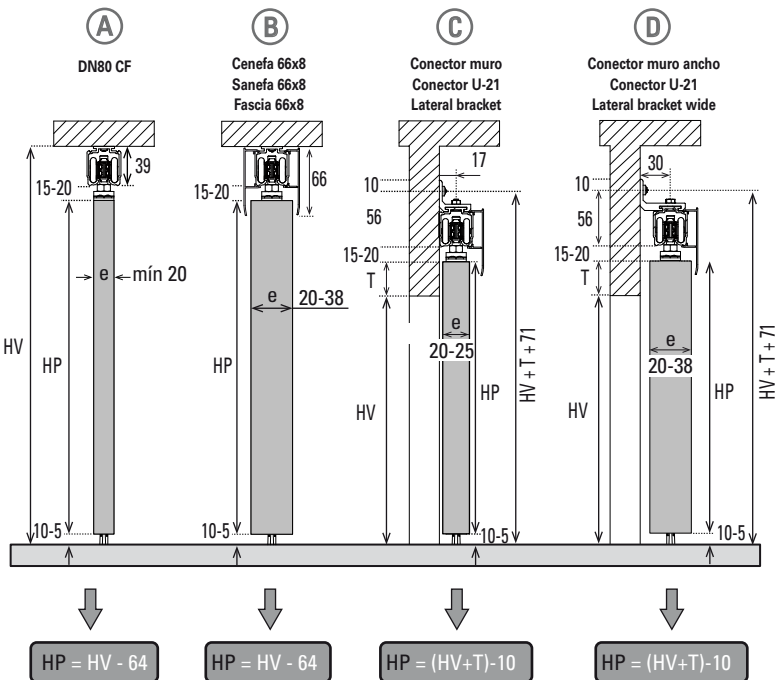

Todas las medidas expresadas en milímetros  
 Todas as medidas estão em milímetros.  
 All measurements in millimeters.

mm	Decimal inches	Aprox Fraction	mm	Decimal inches	Aprox Fraction
1	0.0394	3/64	6	0.2362	15/64
2	0.0787	5/64	7	0.2756	9/32
3	0.1181	1/8	8	0.3150	5/16
4	0.1575	5/32	9	0.3543	23/64
5	0.1969	13/64	10	0.3937	25/64

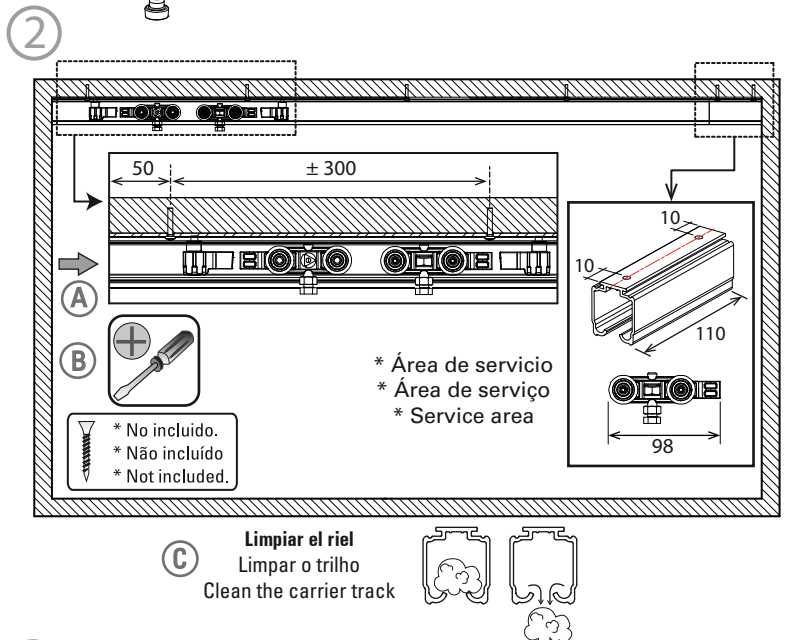
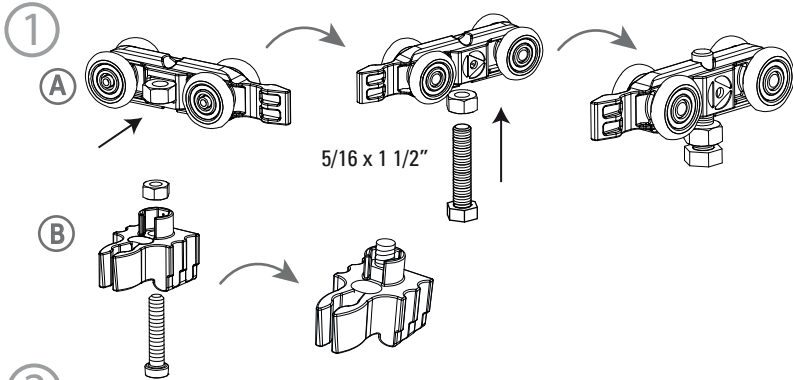

**3** Puerta + paño fijo / Porta + painel fixo / Fixed panel + door

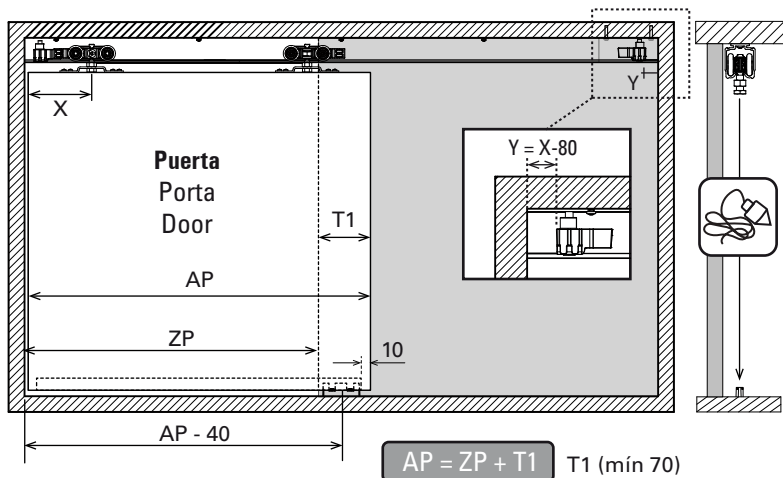

**4** 2 puertas / 2 portas / 2 doors

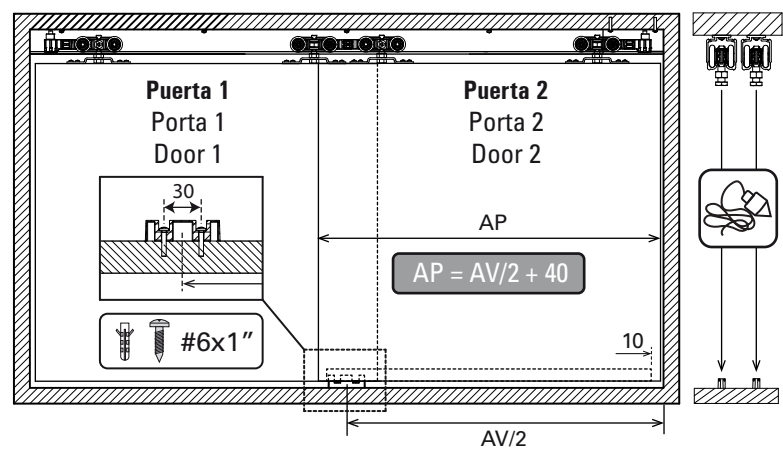

5

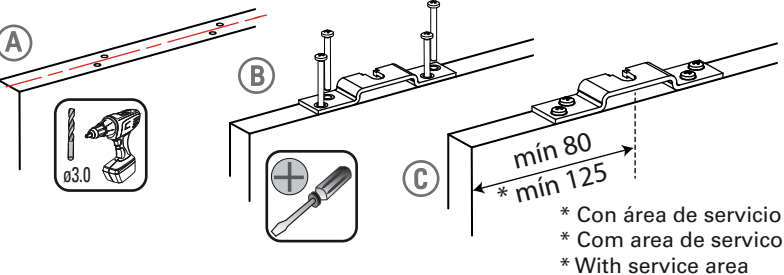

\* Con área de servicio  
 \* Com area de serviço  
 \* With service area

6

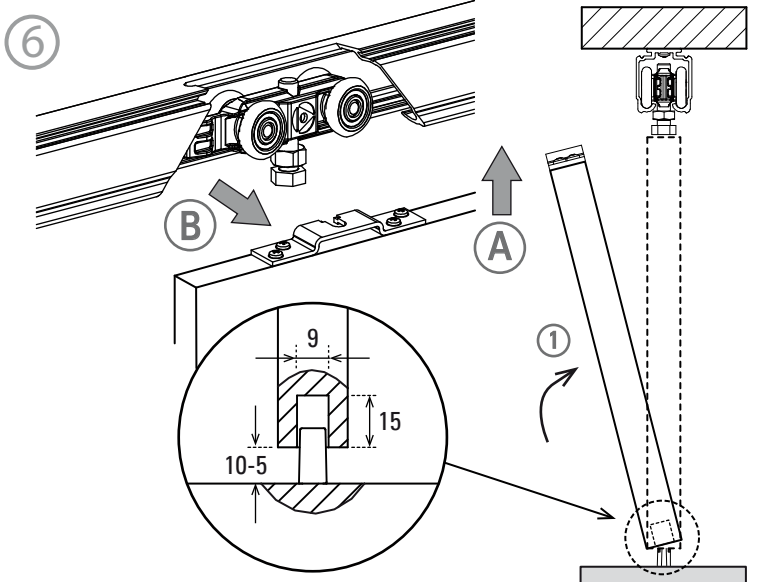

7

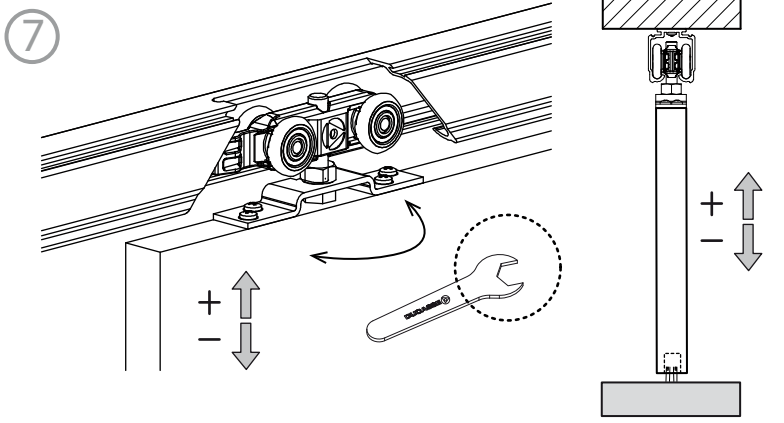

8

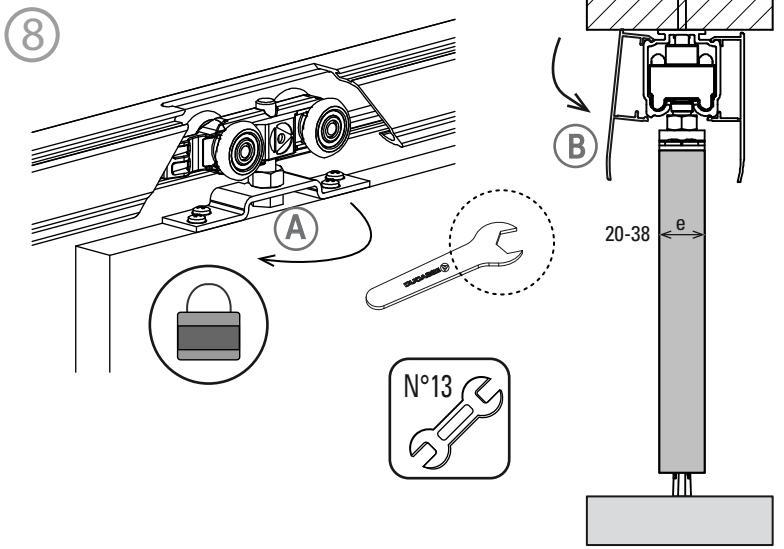

\* ACCESORIOS / ACESSÓRIOS / ACCESSORIES

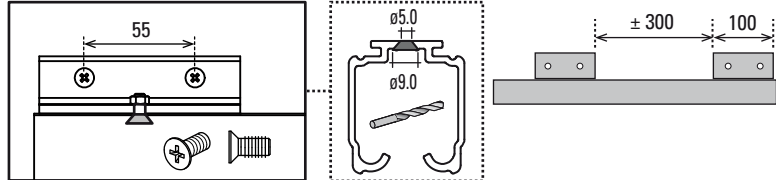
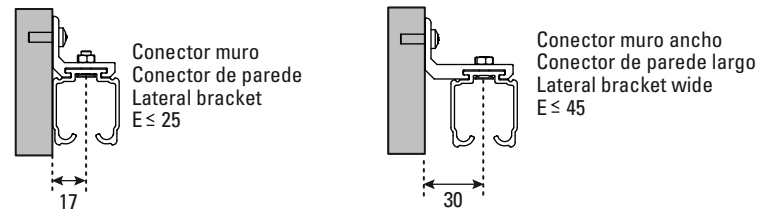

Instrucciones de instalación en [www.ducasseindustrial.com](http://www.ducasseindustrial.com)  
 Instruções de instalação em [www.ducasseindustrial.com](http://www.ducasseindustrial.com)  
 Installation instruction in [www.ducasseindustrial.com](http://www.ducasseindustrial.com)

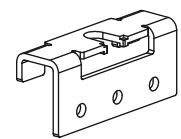

Pletina lateral DN50/80  
 Pletina lateral DN50/80  
 Lateral door bracket DN50/80

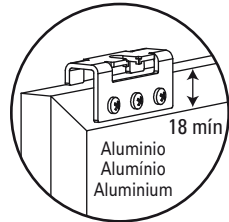
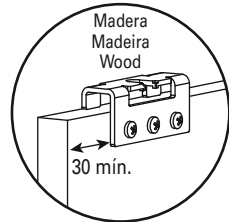

E Cenefa 66x8  
 Sanefa 66x8  
 Fascia U21 66x8

Conector muro ancho / Cenefa 66x8  
 Conector U-21 / Sanefa 66x8  
 Lateral bracket wide / Fascia 66x8

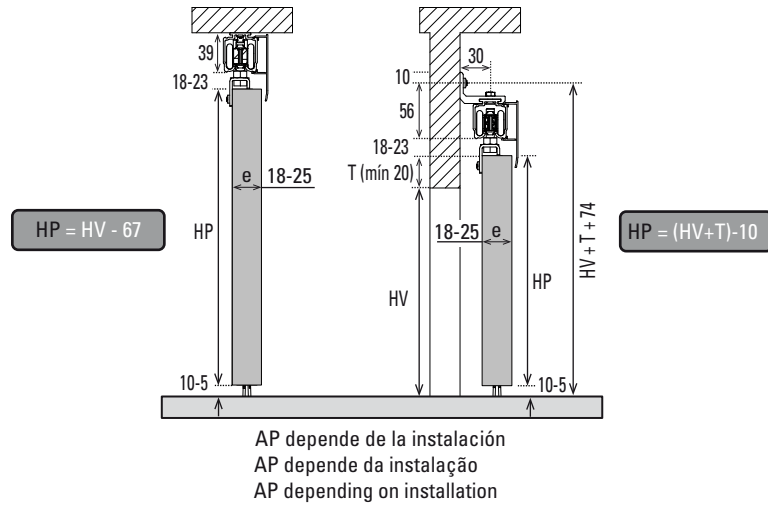

AP depende de la instalación  
 AP depende da instalação  
 AP depending on installation

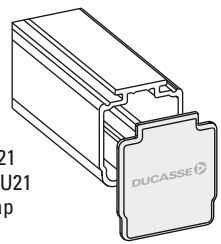

Tapa riel U21  
 Tampa trilho U21  
 U21 end cap

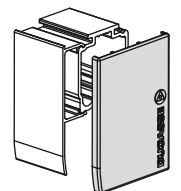

Tapa U21 cenefa 66x8  
 Tampa U21 sanefa 66x8  
 U21 end cap with fascia U21