

CD 30 CX

Madera / Madeira / Wood

1x 15-30kg
33-66 lbs

Peso puerta
Peso porta
Door weight

1

Una puerta
Uma porta
One door

15-20mm
5/8"-13/16"

Espesor Madera
Espessura Madeira
Wood Thickness

Min. 650

Ancho mínimo
Largura mínima
Minimum width

Máx. 2400

Altura máx. puerta
Altura max. porta
Max. Door height

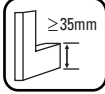
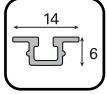

Riel Embutido CX
Trilho Embutido CX
Inlay Carrier Track

COMPONENTES / COMPONENTES / COMPONENTS

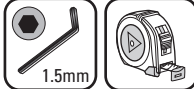
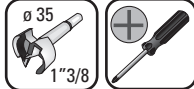
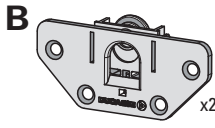
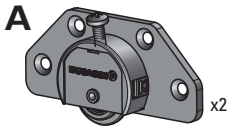

AV = Ancho de vano
HV = Altura de vano
AP = Ancho de puerta
HP = Altura de puerta

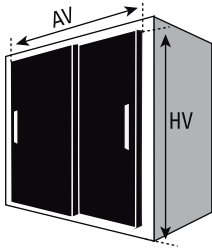

$$HP = HV - 8$$

$$AP = AV/2 + 25$$

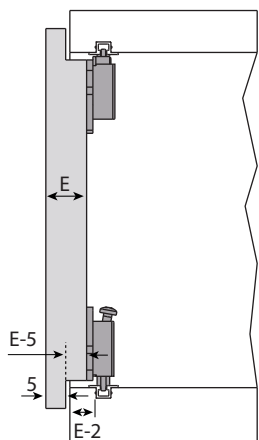
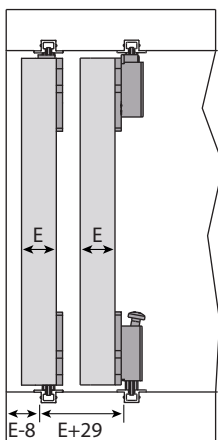
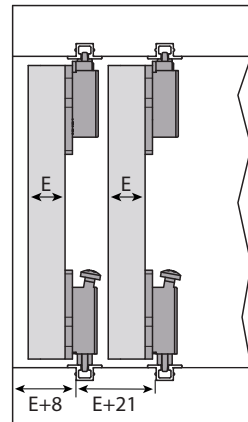
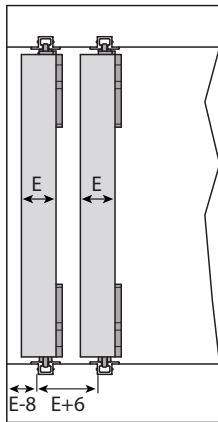

1

1.1

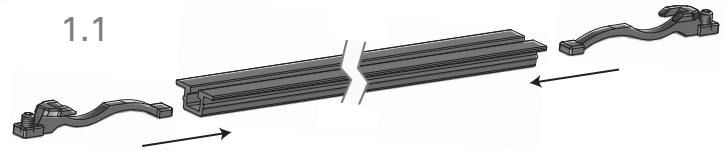

1.2

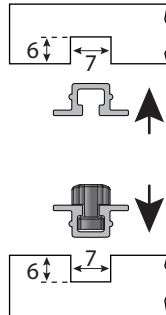

1.3

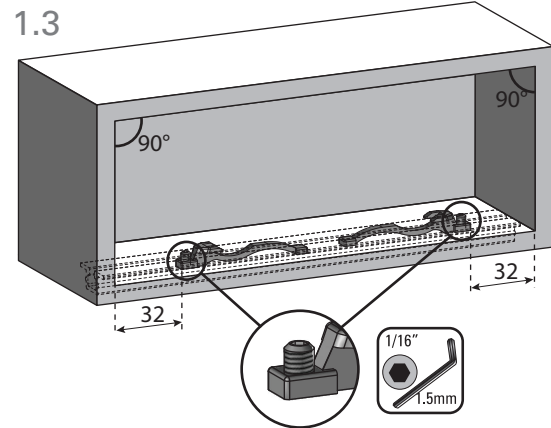

2

Embutido / Embutido / Inlay

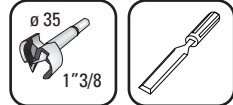

2.1

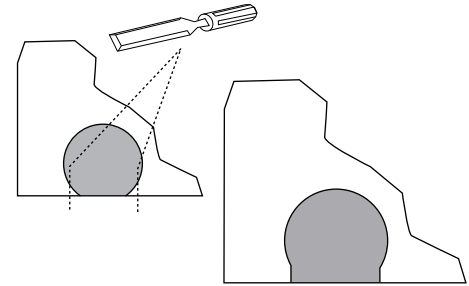
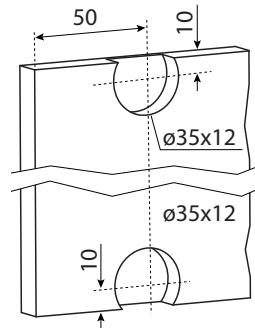

2.2

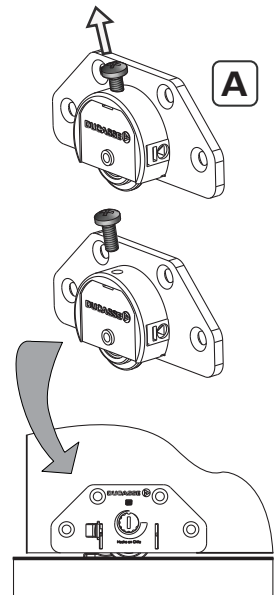
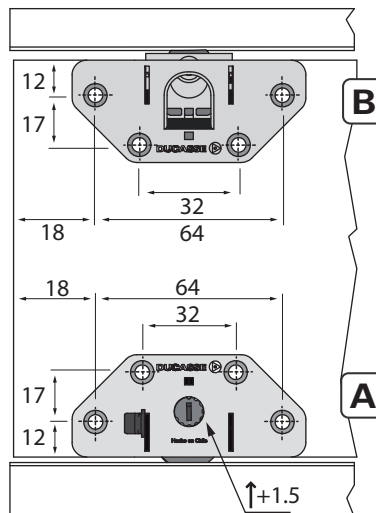
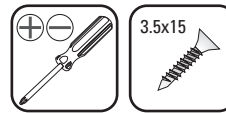

2.3

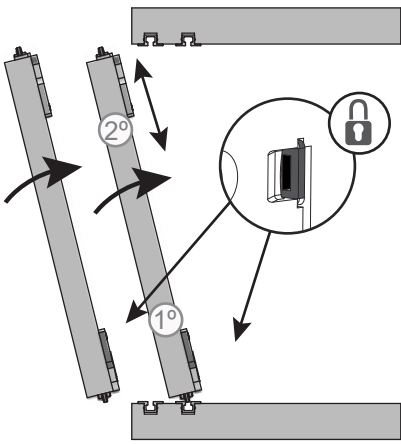

2.4

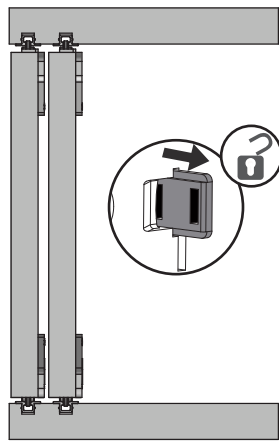

2.5

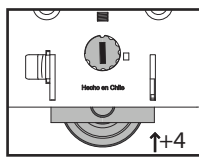
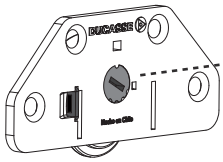

3.4

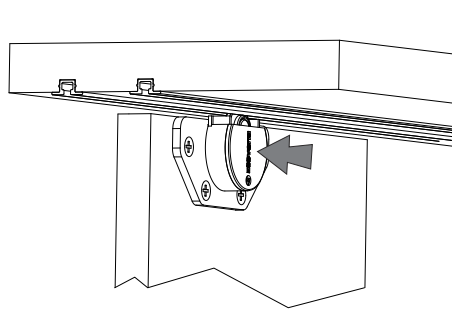

3.5

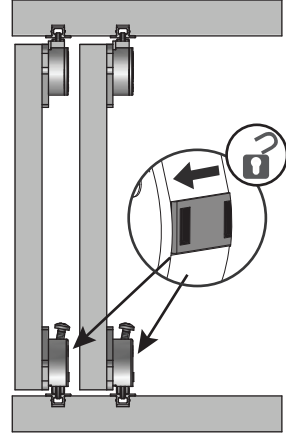

3.6

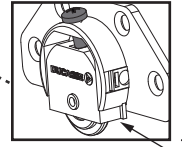
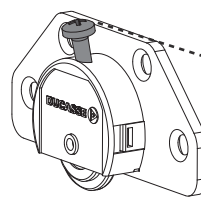

3 Sobrepuesto / Sobreposto / Overlay

B

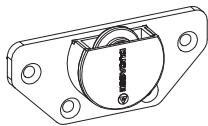

A



3.1

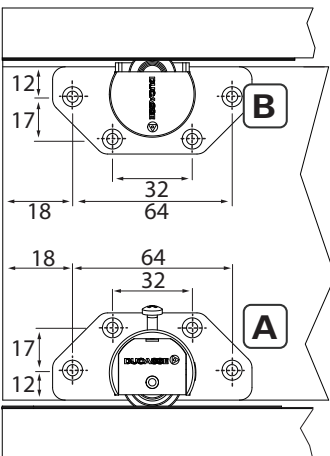

3.2

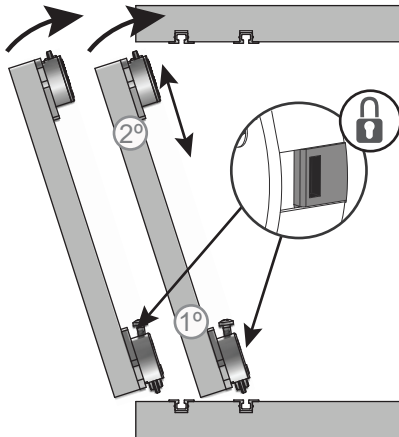

3.3

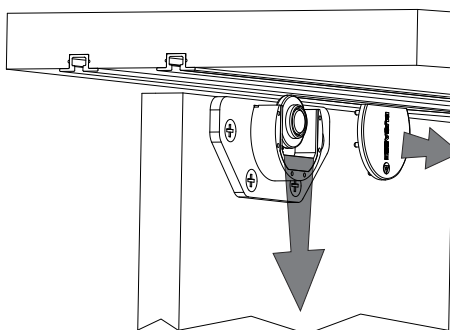

* Accesorios / Accessories

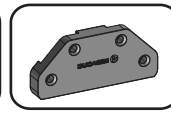

Kit CD-30 SP

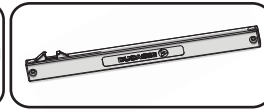
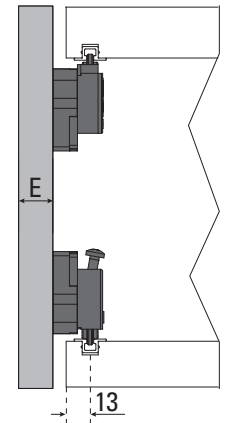

Easy Soft 15

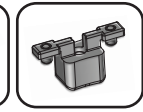

Activador ES15 CX

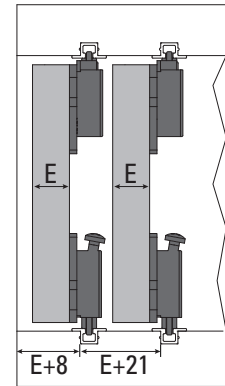
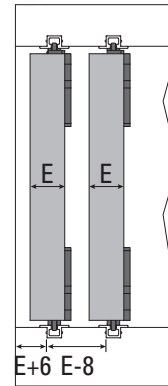

Todas las medidas expresadas en milímetros
 Todas as medidas estão em milímetros.
 All measurements in millimeters.

mm	Decimal inches	Aprox Fraction	mm	Decimal inches	Aprox Fraction
1	0.0394	3/64	6	0.2362	15/64
2	0.0787	5/64	7	0.2756	9/32
3	0.1181	1/8	8	0.3150	5/16
4	0.1575	5/32	9	0.3543	23/64
5	0.1969	13/64	10	0.3937	25/64