

# TWIN TL

- > Instructivo de montaje pg 02
- > Installation Instructions pg 14
- > Instrutivo de montagem pg 26

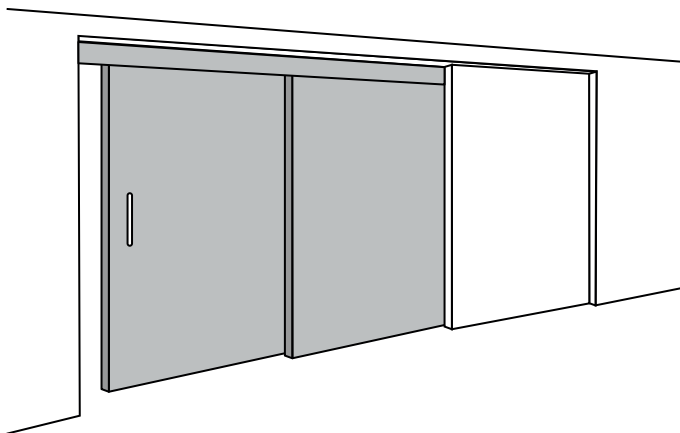

# Índice

TWIN TL es un sistema corredizo sincronizado para puertas de madera de hasta 80 Kg. cada hoja.  
El sistema permite que mediante un solo movimiento se abran ambas puertas sincronizadamente en el mismo sentido.

- 03 Datos generales y dimensionamiento de puertas.
- 04 Detalle de partes y piezas.
- 05 Paso 1: Instalación de riel, carros y frenos.
- 06 Paso 2: Fijación de la guía al suelo.
- 07 Paso 3: Instalación de las bases Twin en las puertas.
- 08 Paso 4: Fijación de la guía telescópica.
- 09 Paso 5: Montaje de las puertas.
- 10 Paso 6: Regulación de altura.
- 11 Paso 7: Fijación de frenos.
- 12 Paso 8: Fijación de la piola.
- 13 Accesorios.

mm	Pulgadas	Fración
1	0.0394	3/64
2	0.0787	5/64
3	0.1181	1/8
4	0.1575	5/32

mm	Pulgadas	Fración
5	0.1969	13/64
6	0.2362	15/64
7	0.2756	9/32
8	0.3150	5/16

mm	Pulgadas	Fración
9	0.3543	23/64
10	0.3937	25/64
11	0.4375	7/16
12	0.4688	15/32

**\*TODAS LAS MEDIDAS ESTÁN INDICADAS EN MILÍMETROS**

## Datos generales y dimensionamiento de puertas



CANTIDAD DE PUERTAS



CAPACIDAD DE CARGA POR HOJA



PARA PUERTAS DE MADERA



ESPESOR PUERTA MADERA



ZONA DE PASO



ANCHO PUERTA

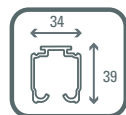

RIEL U21 AL

### Para dimensionar las puertas

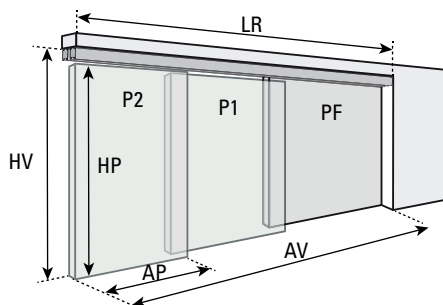

$$APF \geq (AV+2T) / 3$$

$$AP = (ZP + 2T) / 2$$

$$HP = HV - 80$$

$$LR \geq ZP + AP$$

$$HPF = HV$$

$$T \geq 50$$

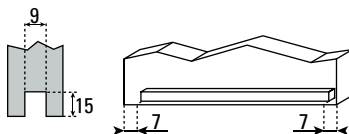
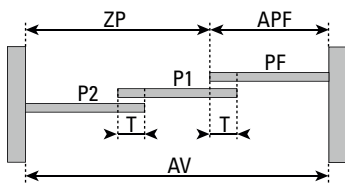

Para las puertas de madera es necesario mecanizar el canto inferior, para permitir el paso de la guía.

**AP = Ancho Puerta | AV = Ancho Vano | HP = Altura Puerta | HV = Altura Vano**  
**HPF = Altura Paño Fijo | APF = Ancho Paño Fijo | ZP = Zona de Paso | T = Traslape | LR = Largo Riel**

## Detalle de partes y piezas

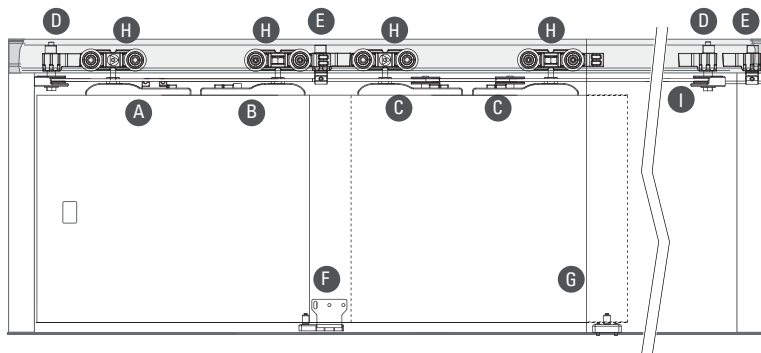

### TWIN TL

<b>A</b>	Base candado desmontable		1
<b>B</b>	Bases Twin		1
<b>C</b>	Bases Polea Twin		2
<b>D</b>	Frenos Polea Twin		2
<b>E</b>	Frenos candado		2
<b>F</b>	Guía telescópica		1
<b>G</b>	Guía alta GPR		1
<b>H</b>	Carros DN 80		4
<b>I</b>	Piola 10.5 mt		1
<b>J</b>	Llave Segmenta		2
<b>K</b>	Llave Allen 2.5mm		1
<b>L</b>	Tornillos para madera #4.5 x 45		12
<b>M</b>	Rosc. C/ pan Ranura # 8 X 1"		2
<b>N</b>	Tarugos Nylon M6		2
<b>O</b>	Rosc. Binding # 6 x 1/2".		3

### HERRAMIENTAS NECESARIAS

Taladro	
Brocas ø3 / ø6	
Plomo	
Destornillador cruz	
Huinchita de medir	



# Instalación de riel, carros y frenos

## Paso 1

- Cortar los rieles según la fórmula indicada y luego perforar.

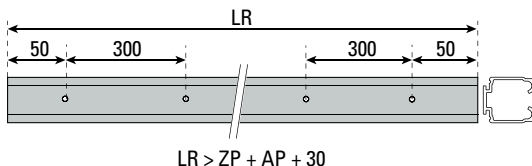

- Introducir carros y frenos candado por ambos extremos del riel 1 (R1), en las posiciones que indica el esquema.

- De igual forma, introducir carros y frenos polea por ambos extremos del riel 2 (R2).

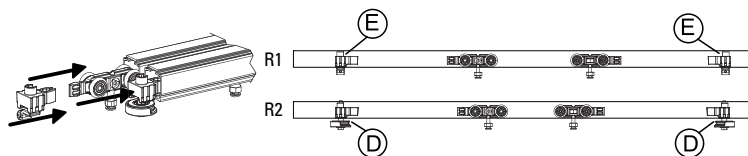

Nota: Riel 1 (R1) para puerta 1 (P1) | Riel 2 (R2) para puerta 2 (P2)

- Fijar los rieles al cielo, tomando en cuenta la distancia indicada en el esquema. (Fijaciones no incluidas).

- Después de fijar, limpiar las pistas de los rieles para evitar posibles residuos.

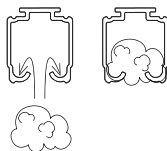
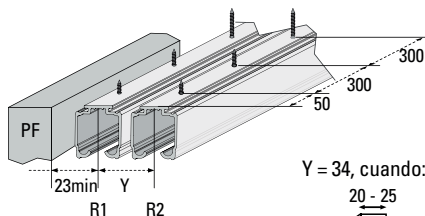

Y = 34, cuando:

20 - 25



Y = E + 9, cuando:

26 - 35



Y = 53, cuando:

45



## Paso 2

### Fijación de la guía al suelo

- Aplomar riel 1 (R1) para determinar la posición de la guía alta GPR.

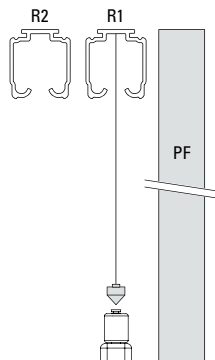

- Perforar el suelo con broca diámetro 6mm para fijar la guía en su posición, justo al término del paño fijo (PF), tal como lo indica el esquema.

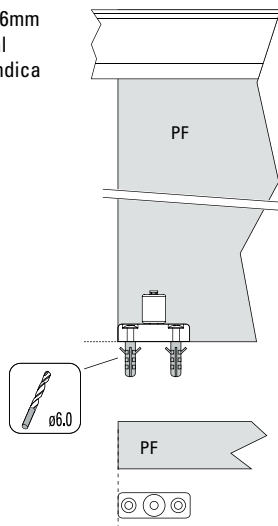

- En el canto superior de la puerta 1 (P1), fijar las bases polea Twin con las poleas hacia el centro de la puerta, y como mínimo a 55mm del borde.



- En la puerta 2 (P2), fijar la base candado desmontable y la base Twin, tal como lo indica el esquema y tomando en cuenta los 55mm mínimo del borde.





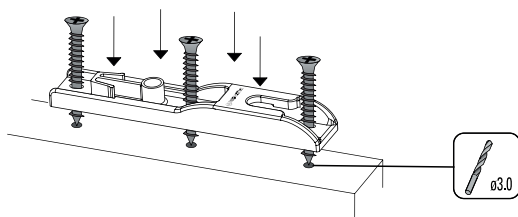

Hacer perforación guía con broca diámetro 3mm, para poder fijar las bases Twin con los tornillos 4.5x45.

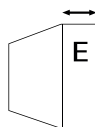
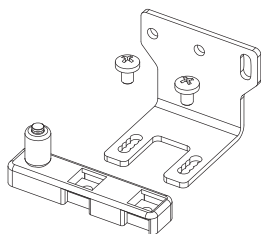

## Paso 4

- Configurar la guía telescópica según el tipo y espesor de la puerta, tal como se indica en el esquema.



A		E= 22 - 29
B		E= 20, 21, 30-34
C		E= 35
D		E= 45

- Fijar guía telescópica por el lado interior de la puerta 1 (P1), dejando 7mm de distancia entre el canto de la puerta y el centro de la primera perforación, y 22mm entre el borde inferior hasta el centro de las perforaciones; utilizando los tornillos Rosca Binding #6 x 1" (O).

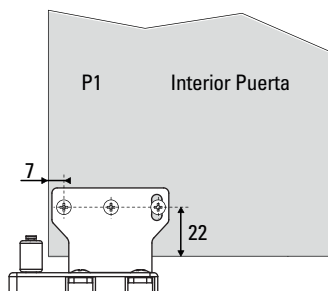
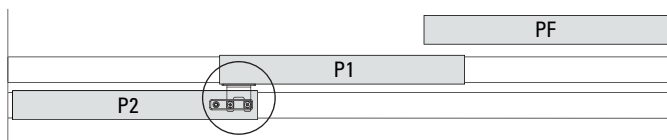

- Montar la puerta 1 (P1) en guía GPR, cuidando de no dañar la guía TL. Luego, introducir los pernos en las placas.
- Montar con precaución la puerta 2 (P2) sobre guía TL e introducir los pernos en las placas.

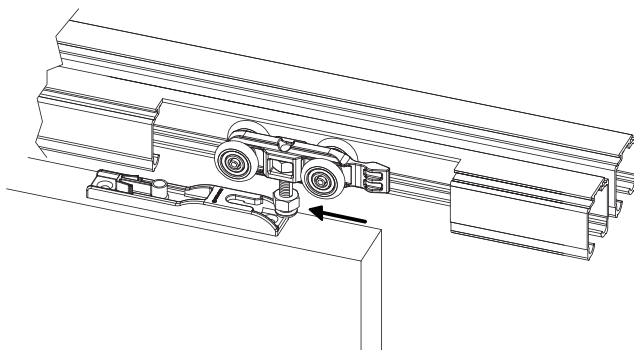
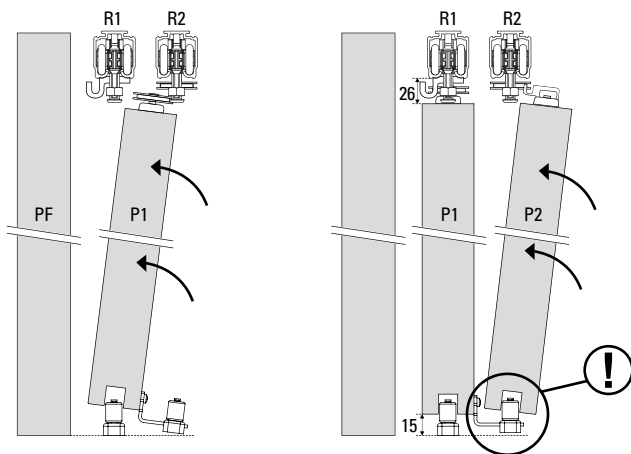

## Paso 6

- Con la llave Segmenta regular la altura de la puerta girando el perno destaje completo.

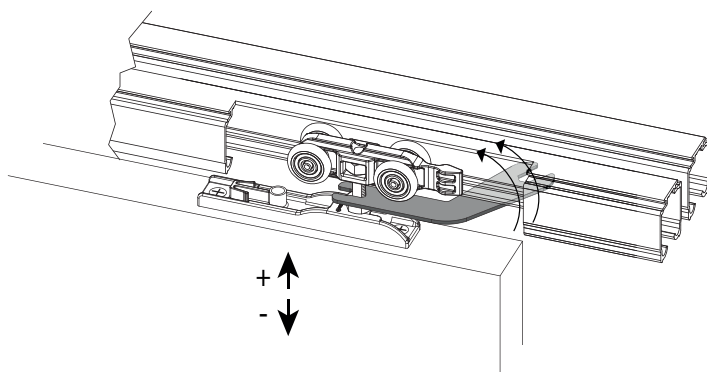

- Luego fijar la contratuerca utilizando ambas llaves Segmenta, una girando el perno y la otra la tuerca en sentido opuesto.

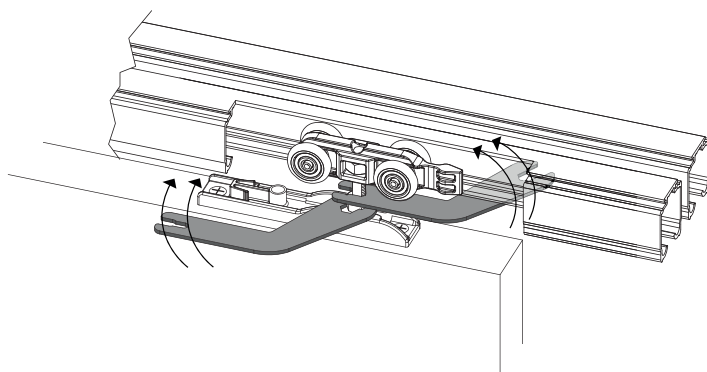

- Llevar las puertas ya montadas a su posición cerrada para poder fijar los frenos. Para ello, es necesario moverlos hasta encajarlos con los carros y fijarlos en esa posición.

- El freno candado (E) se fija en la puerta 1 (P1) con destornillador y el freno polea (D) se fija en la puerta 2 (P2) con la llave Segmenta

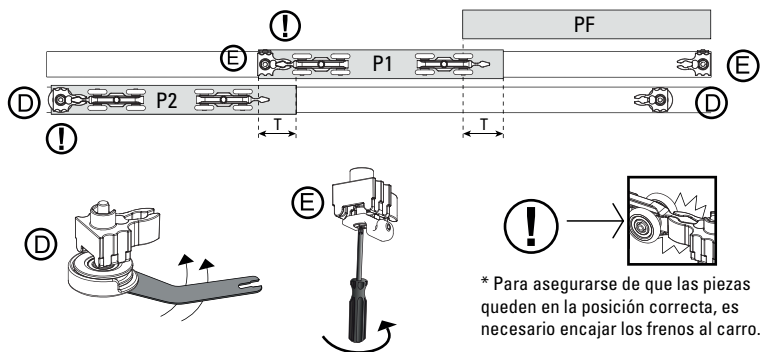

- Luego, para fijar los frenos restantes es necesario llevar las puertas a su posición abierta, mover los frenos hasta encajarlos con los carros y fijarlos en esa posición.

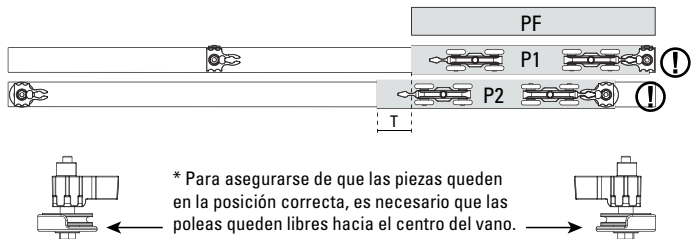

- Para lograr una terminación óptima, es necesario tener en cuenta las medidas mínimas de traslape (T).



# Paso 8

- Con las puertas cerradas, colocar la piola siguiendo los pasos y el recorrido indicado por el esquema, partiendo por ajustarla en el freno candado de la puerta 1 (P1) con llave Allen 2.5mm.

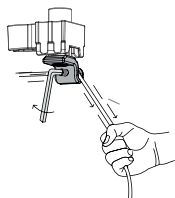

\* El candado del freno tiene la posibilidad de girarse en caso de tener instalaciones inversas. También ofrece la posibilidad de fijar la piola por ambas caras del candado, lo que facilita la instalación.

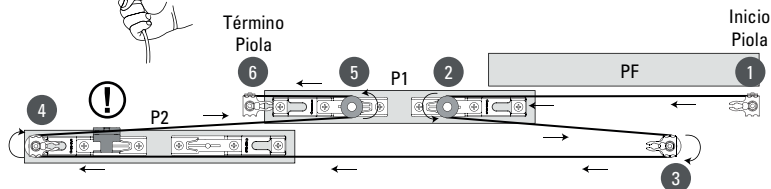

- Después, tensar la piola y fijarla en el otro freno candado.

- Una vez fijados los frenos candados, fijar la piola al candado de la base.

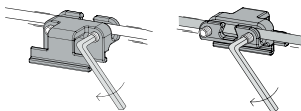
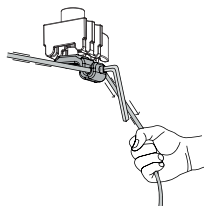

! El candado puede ser desmontado de la base Twin y montado hacia el otro lado, en el caso de tener instalaciones inversas. Para ello se deben presionar las pestañas ubicadas en la base, tal como muestra el esquema.

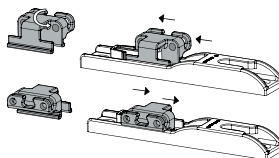
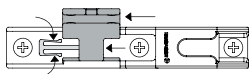



## Accesorios

- 1 CENEFA U-21 66x8
- 2 CENEFA U-21 120x8
- 3 TAPA U-21 CENEFA 66x8
- 4 TAPA U-21 CENEFA 120x8

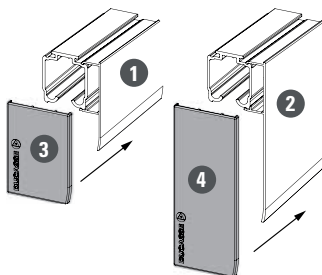

# Index

TWIN TL is a synchronized sliding system for wooden doors of up to 80 Kg.  
each sheet.

The system allows the synchronized, same direction opening of both doors  
with only a single movement.

- 15 General data and door sizing.
- 16 Detail of parts and pieces.
- 17 Step 1: Track, carriers and stoppers installation.
- 18 Step 2: Set-up of the guide to the floor.
- 19 Step 3: Installing Twin bases on doors.
- 20 Step 4: Set-up of the telescopic guide.
- 21 Step 5: Doors mounting.
- 22 Step 6: Height regulation.
- 23 Step 7: Stoppers set-up.
- 24 Step 8: Cable set-up.
- 25 Accessories.

mm	Pulgadas	Fracción
1	0.0394	3/64
2	0.0787	5/64
3	0.1181	1/8
4	0.1575	5/32

mm	Pulgadas	Fracción
5	0.1969	13/64
6	0.2362	15/64
7	0.2756	9/32
8	0.3150	5/16

mm	Pulgadas	Fracción
9	0.3543	23/64
10	0.3937	25/64
11	0.4375	7/16
12	0.4688	15/32

**\*ALL MEASUREMENTS ARE EXPRESSED IN MILLIMETERS**

## General data and door sizing



NUMBER OF DOORS



LOAD CAPACITY PER SHEET



FOR WOODEN DOORS



WOODEN DOORS THICKNESS



TRANSIT AREA



DOOR WIDTH

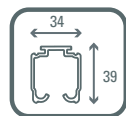

TRACK U21 AL

### Doors sizing

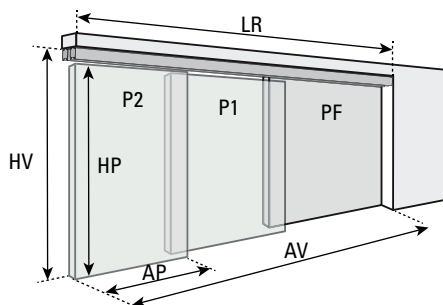

$$APF \geq (AV + 2T) / 3$$

$$AP = (ZP + 2T) / 2$$

$$HP = HV - 80$$

$$LR \geq ZP + AP$$

$$HPF = HV$$

$$T \geq 50$$

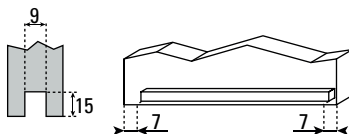
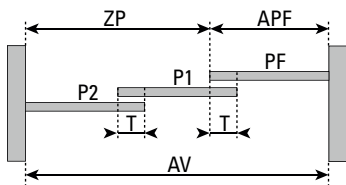







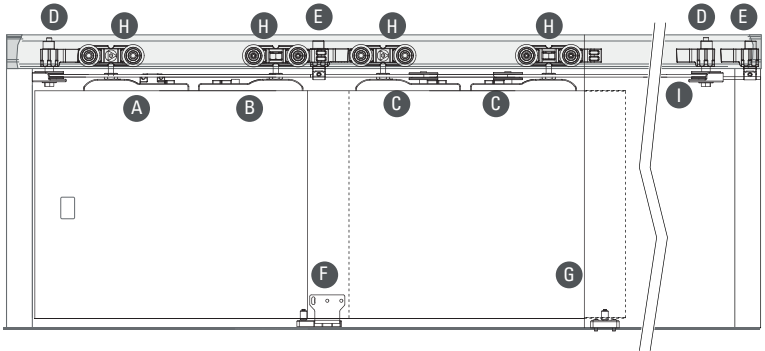







For wooden doors it is necessary to mechanize the bottom edge to allow the guide to pass.

**AP = Door Width | AV = Opening Width | HP = Door Height | HV = Opening Height**  
**HPF = Fixed Panel Height | APF = Fixed Panel Width | ZP = Transit Area | T = Overlap | LR = Track Length**





## Details of parts and pieces



### TWIN TL

<b>A</b>	Detachable lock base		1
<b>B</b>	Twin bases		1
<b>C</b>	Twin pulley bases		2
<b>D</b>	Twin pulley stoppers		2
<b>E</b>	Lock stoppers		2
<b>F</b>	Telescopic guide		1
<b>G</b>	High GPR guide		1
<b>H</b>	DN 80 Carriers		4
<b>I</b>	10.5 m. of cable		1
<b>J</b>	Segmenta key		2
<b>K</b>	Allen Key 2.5 mm		1
<b>L</b>	Wood screws #4.5 x 45		12
<b>M</b>	Slotted pan head screws # 8 X 1"		2
<b>N</b>	Nylon dowels M6		2
<b>O</b>	Binding screws # 6 x 1/2"		3

### NECESSARY TOOLS

Drill	
Drill bits ø3 / ø6	
Plumb line	
Phillips screwdriver	
Measuring tape	

# Track, carriers and stoppers installation.

## Step 1

- Cut the tracks according to the following formula and then, drill.

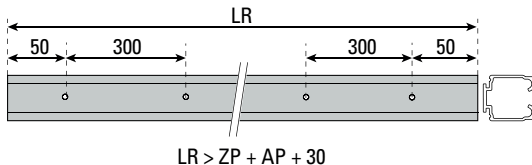

- Insert carriers and lock stoppers in both ends of the track 1 (R1), as shown in the diagram.

- Similarly, insert the carriers and pulley stoppers at both ends of the track 2 (R2).

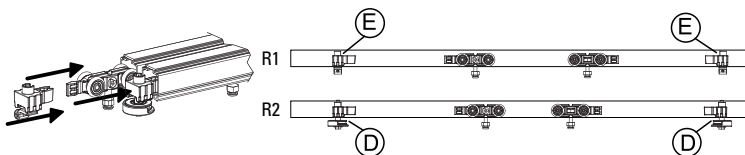

Note: Track 1 (R1) for port 1 (P1) | Track 2 (R2) for port 2 (P2)

- Fix the tracks to the ceiling. Take into consideration the distance which is shown in the drawing. (Fixtures not included).

- After fixing, clean the track grooves to avoid possible leftover residues.

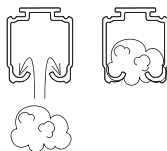
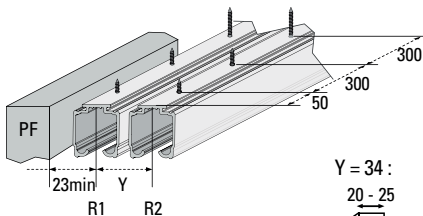

Y = 34 :

20 - 25



Y = E + 9 :

26 - 35



Y = 53 :

45



## Step 2

### Set-up of the guide to the floor

- Plumb track 1 (R1) to determine the high GPR guide position.

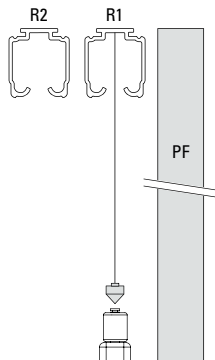

- Drill the floor with a 6mm diameter drill bit to set the guide in place, just at the end of the fixed panel (PF), as shown in the diagram.

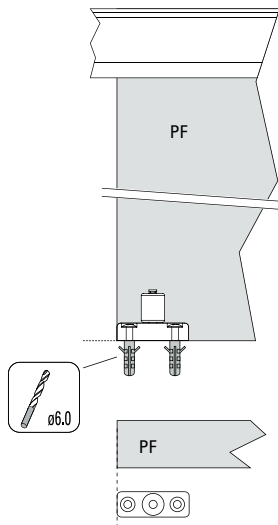

## Installing Twin bases on doors.

### Step 3

- At the upper edge of the door 1 (P1), fix the Twin pulley bases with the pulleys towards the center of the door, and at least 55mm from the edge.



- At the door 2 (P2), fasten the base removable lock and the Twin base, as shown in the diagram, considering a minimum distance of 55mm from the edge.



- Drill the guide with a 3mm diameter drill bit to fix the Twin bases with 4.5x45 screws.

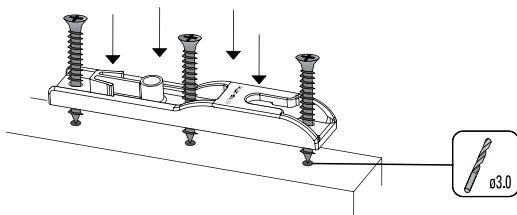

## Step 4

- Set the telescopic guide according to the type and thickness of the door, as indicated in the diagram.

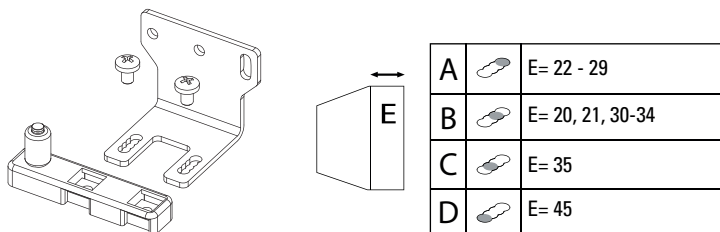

- Fix the telescopic guide on the inside of the door 1 (P1), leaving 7mm distance between the door edge and the center of the first hole, and 22mm from the bottom edge to the center of the holes. Use the binding screw # 6 x 1/2" (O).

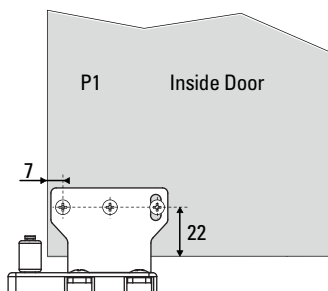
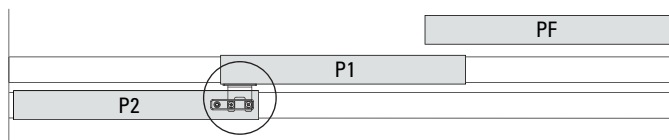



- Assemble the door 1 (P1) in GPR guide, taking care not to damage the TL guide. Then, insert the pins on the plates.
- Assemble with care door 2 (P2) on TL guide and insert the pins on the plates.

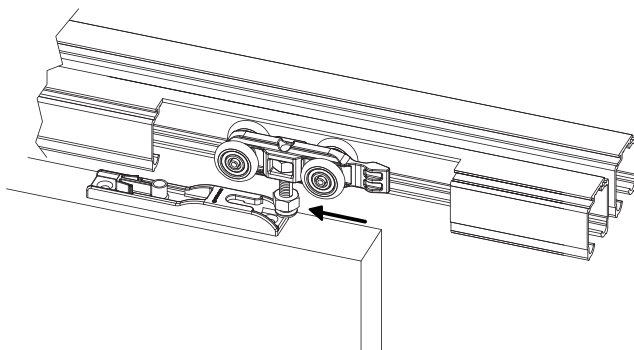
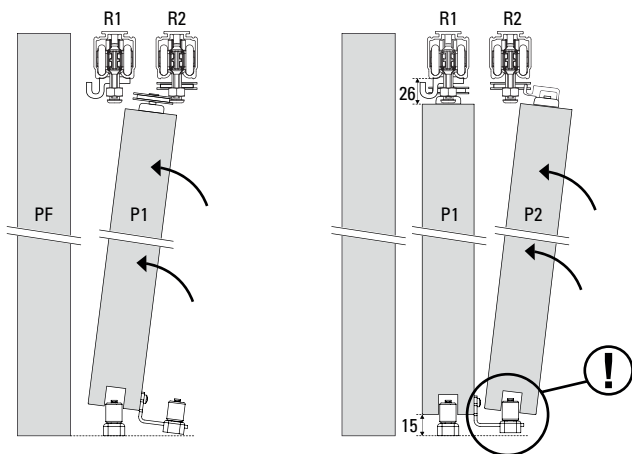

## Step 6

- Using the Segmenta key adjust the height of the door turning the bolt completely.

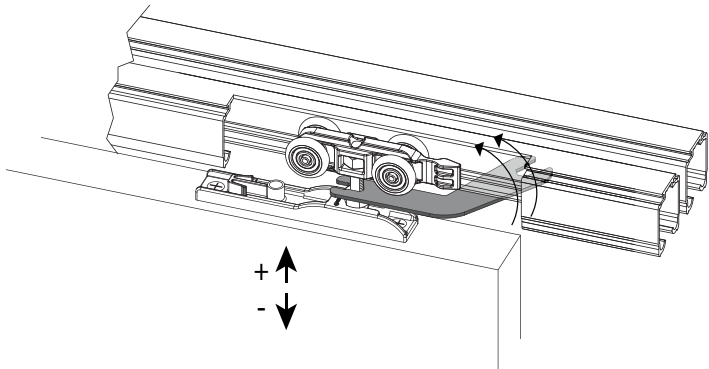

- Then, fix the lock nut using the two Segmenta keys; one rotating the bolt and the other, the nut on the opposite direction.

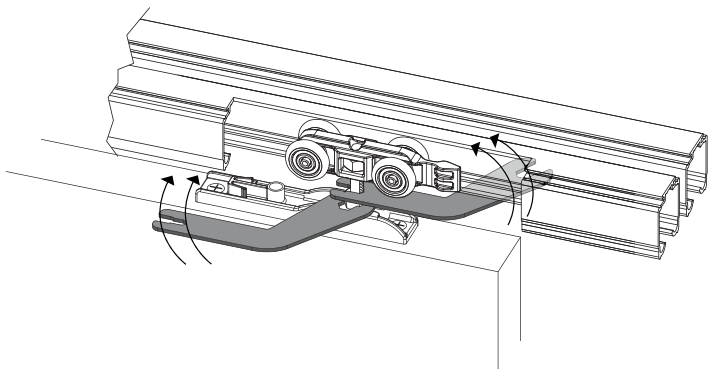

- Keep mounted doors in its closed position to fix the stoppers. To do this, you need to move them until they fit with the carriers and then, fix them in that position.

- The lock stopper (E) is set on door 1 (P1) with a screwdriver and the pulley stopper (D) must be fixed on the door 2 (P2) using Segmenta key.

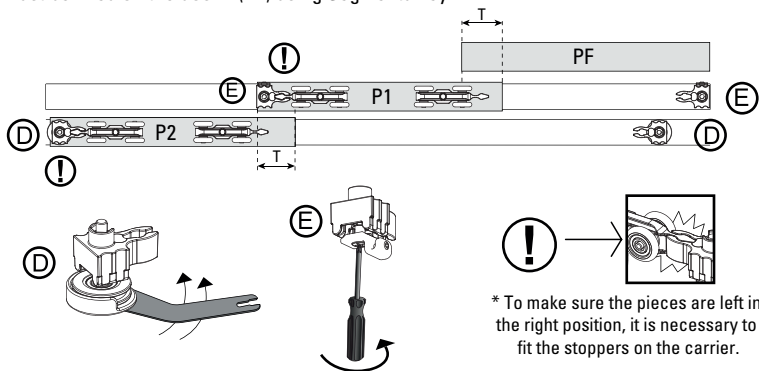

- Then, to fix the remaining stoppers it is necessary to bring the doors to a open position, move the stoppers until fitting them with the carriers and fix them in that position.

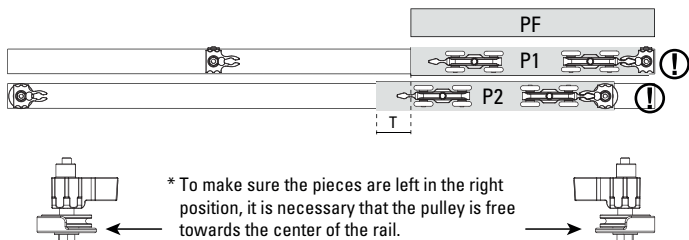

- To achieve an optimal termination it is necessary to consider the minimum measures of overlapping (T).



## Step 8

- With the doors closed, place the cable following the steps and the path indicated in the diagram. Start the process by adjusting it on the lock stopper of the door 1 (P1) using a 2.5mm Allen key.

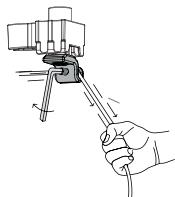

\* The lock stopper has the ability to turn in case of inverse facilities. It also offers the possibility to set the cable on both sides of the lock, which makes installation easy.

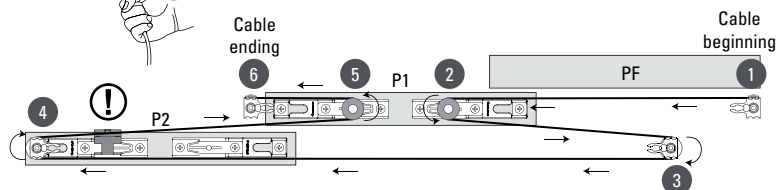

- Then, tighten the cable and set it on the other lock stopper.

- Once the lock stoppers are fixed, fix the cable to the lock of the base.

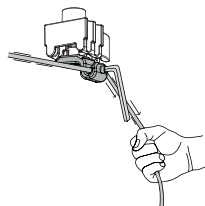
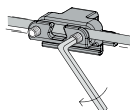
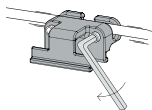

The lock can be disassembled from the Twin base and assembled to the other side if the facility is reversed. To do this, you need to press the tabs at the base, as shown in the diagram.

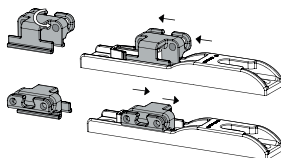
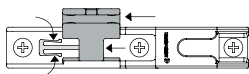

## Accessories

- 1 FASCIA U-21 66x8
- 2 FASCIA U-21 120x8
- 3 END CAP FASCIA U-21 66x8
- 4 END CAP FASCIA U-21 120x8

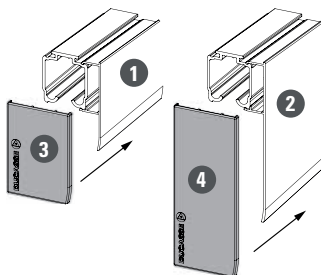

# Índice

TWIN TL é um sistema de correr sincronizado suspenso para portas de madeira de até 80 kg por porta.

O sistema permite que com um único movimento se abram as duas portas simultaneamente deslizando ambas no mesmo sentido de abertura.

- 27 Dados gerais e dimensionamento das portas.
- 28 Detalhe das partes e peças.
- 29 Passo 1: Instalação do trilho, carros e freios.
- 30 Passo 2: Fixação da guia no piso.
- 31 Passo 3: Instalação das placas nas portas.
- 32 Passo 4: Fixação da guia telescópica.
- 33 Passo 5: Montagem das portas.
- 34 Passo 6: Regulagem de altura.
- 35 Passo 7: Fixação dos freios.
- 36 Passo 8: Fixação do cabo.
- 37 Acessórios.

mm	Pulgadas	Fracção
1	0.0394	3/64
2	0.0787	5/64
3	0.1181	1/8
4	0.1575	5/32

mm	Pulgadas	Fracção
5	0.1969	13/64
6	0.2362	15/64
7	0.2756	9/32
8	0.3150	5/16

mm	Pulgadas	Fracção
9	0.3543	23/64
10	0.3937	25/64
11	0.4375	7/16
12	0.4688	15/32

**\*TODAS AS MEDIDAS ESTÃO INDICADAS EM MILÍMETROS**

## Dados gerais e dimensionamento das portas



QUANTIDADE  
DE PORTAS



CAPACIDADE DE  
CARGA POR PORTA



PARA PORTAS  
DE MADEIRA



ESPESSURA PORTA  
MADEIRA



VÃO DE PASSAGEM



LARGURA DA  
PORTA

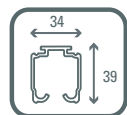

TRILHO U21  
PARA SANEFA

### Para dimensionar as portas

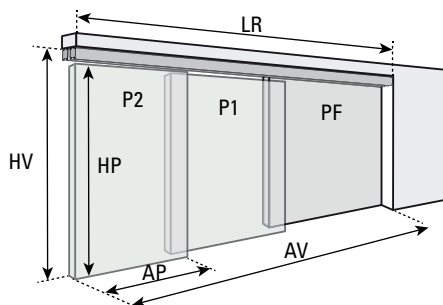

$$APF \geq (AV + 2T) / 3$$

$$AP = (ZP + 2T) / 2$$

$$HP = HV - 80$$

$$LR \geq ZP + AP$$

$$HPF = HV$$

$$T \geq 50$$

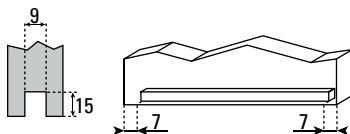
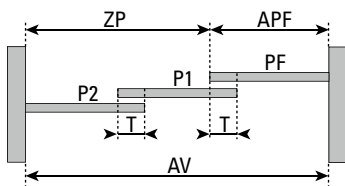

Para portas de madeira é necessário usar a parte inferior para permitir o deslizamento da guia.

**AP = Largura da porta | AV = Largura do vão | HP = Altura da porta | HV = Altura do vão**  
**HPF = Altura do painel fixo | APF = Largura do painel fixo | ZP = Vão de passagem**  
**T = Transpasse | LR = Comprimento trilho**

## Detalhe das partes e peças

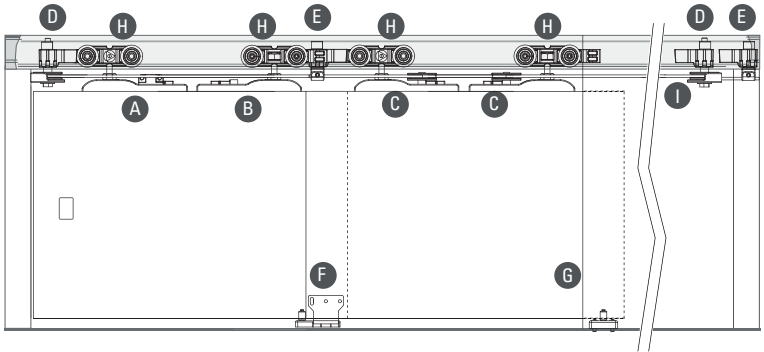

### TWIN TL

<b>A</b>	Placa com presilha desmontável		1
<b>B</b>	Placa simples		1
<b>C</b>	Placa com roldana		2
<b>D</b>	Freios com roldana		2
<b>E</b>	Freios com presilha		2
<b>F</b>	Guia telescópica		1
<b>G</b>	Guia alta GPR		1
<b>H</b>	Carros DN80		4
<b>I</b>	Cabo 10,5 m		1
<b>J</b>	Chave Segmenta		2
<b>K</b>	Chave Allen 2,5 mm		1
<b>L</b>	Parafuso para madeira #4,5 x 45		12
<b>M</b>	Parafuso cab. pan. #8 x 1"		2
<b>N</b>	Bucha Nylon M6		2
<b>O</b>	Parafuso cab. pan. ponta broca #6 x 1/2"		3

### FERRAMENTAS NECESSÁRIAS

Parafusadeira	
Brocas ø3 / ø6	
Prumo	
Chave fenda philips	
Fita métrica	



- Cortar os trilhos conforme a fórmula indicada e perfurar.

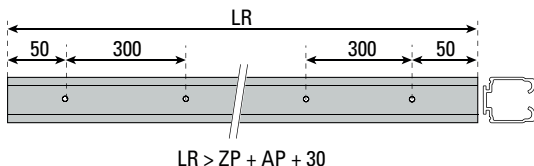

- Introduzir os carros e freios com presilha em ambas as extremidades do trilho 1 (R1), nas posições indicadas no desenho.

- Da mesma forma, introduzir os carros e freios com roldana em ambas as extremidades do trilho 2 (R2).

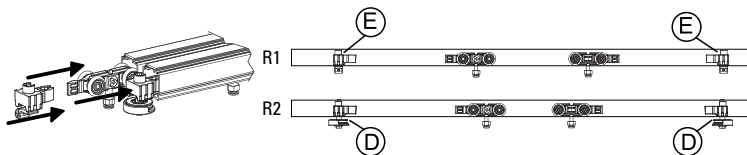

Nota: Trilho 1 (R1) para porta 1 (P1) | Trilho 2 (R2) para porta 2 (P2)

- Fixar os trilhos no teto, considerando a distância indicada no desenho (parafusos e buchas não inclusos).

- Depois de fixar, limpar os canais dos trilhos para evitar a permanência de possíveis resíduos.

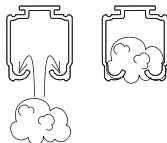
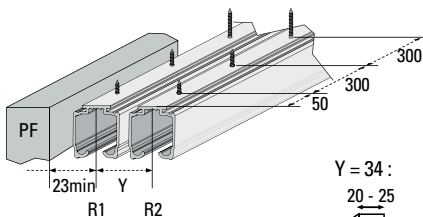

Y = 34 :  
20 - 25



Y = E + 9 :  
26 - 35



Y = 53 :  
45



## Passo 2

- Aprumar o trilho 1 (R1) para determinar a posição da guia de piso.

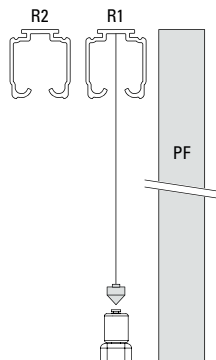

- Perfurar o piso com broca de diâmetro 6 mm para fixar a guia em sua posição, junto ao final do painel fixo (PF), assim como indicado no desenho.

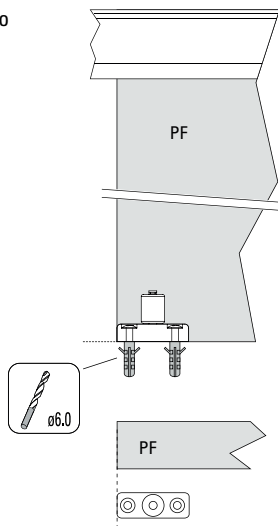

- No canto superior da porta 1 (P1), fixar as placas com roldana com as roldanas voltadas para o centro da porta, e no mínimo a 55 mm da lateral da porta.



- Na porta 2 (P2), fixar a placa com presilha e a placa simples, conforme indicado no desenho e considerando o recuo mínimo de 55 mm da lateral da porta.





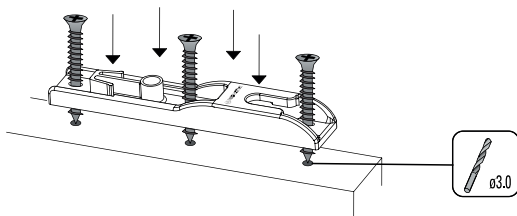

- Fazer pré-furação com broca diâmetro 3 mm, para poder fixar as placas com p arafusos 4,5 x 45.

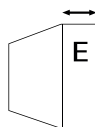
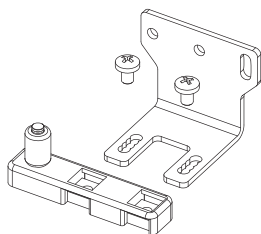

## Passo 4

- Regular a guia telescópica conforme o tipo e espessura da porta, assim como indicado abaixo.



A		E= 22 - 29
B		E= 20, 21, 30-34
C		E= 35
D		E= 45

- Fixar a guia telescópica pelo lado interno da porta (P1), deixando 7 mm de distância entre o canto da porta e o centro da primeira perfuração, e 22 mm entre a borda inferior até o centro das perfurações; utilizando os parafusos cab. pan. ponta broca #6 x 1/2" (O).

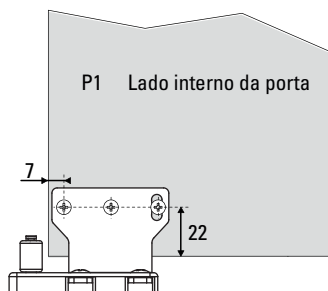
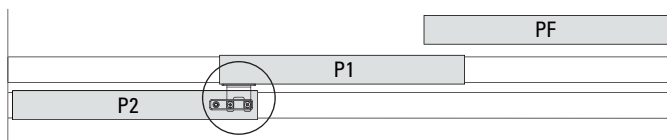

- Encaixar a porta 1 (P1) na guia de piso, cuidando para não danificar a guia TL. Em seguida, introduzir os parafusos dos carros nas placas já fixadas na porta.
- Encaixar com cuidado a porta 2 (P2) sobre a guia TL e introduzir os parafusos dos carros nas placas.

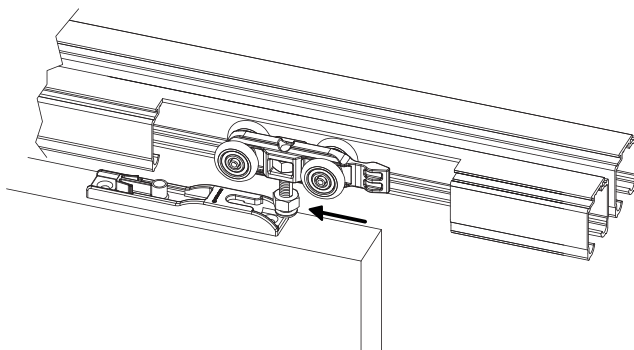
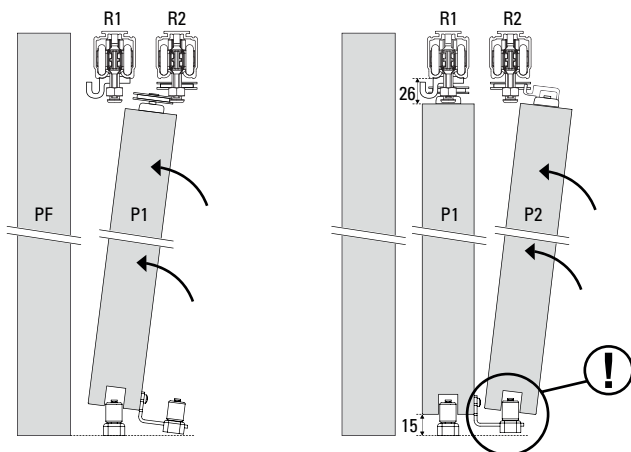

## Passo 6

- Com a chave Segmenta regular a altura da porta girando o parafuso dos carros.

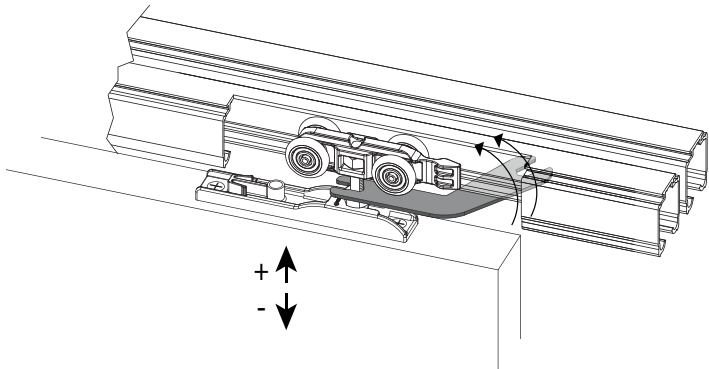

- Em seguida fixar a porca do carro utilizando ambas as chaves Segmenta, uma segurando o parafuso e outra girando a porca no sentido oposto até travar contra a placa.

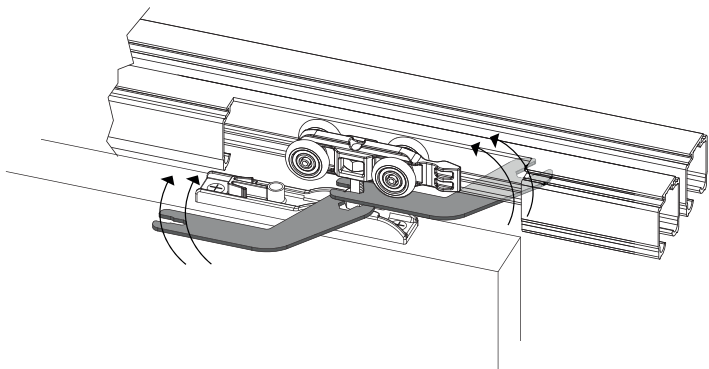

- Mover as portas já instaladas para sua posição fechada distribuindo o transpasse entre as portas. Deslizar os freios até encaixar nos carros e fixa-los nessa posição.

- O freio com presilha (E) é instalado na porta 1 (P1) com chave philips e o freio com rolda na (D) é instalado na porta 2 (P2) com a chave Segmenta.

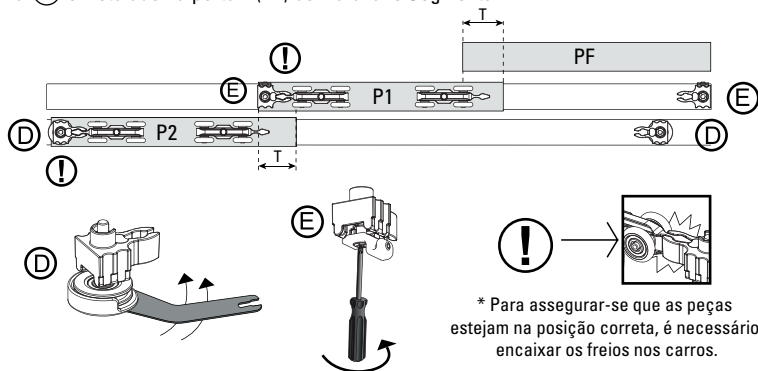

- Em seguida, para fixar os freios restantes é necessário mover as portas até sua posição aberta, deslizar os freios até encaixar nos carros e fixa-los nessa posição.

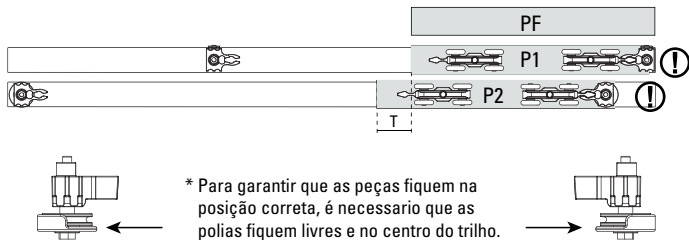

- Para ter um ótimo acabamento é necessário considerar as medidas mínimas de transpasse (T).



## Passo 8

- Com as portas fechadas, colocar o cabo seguindo os passos e o percurso indicados no desenho a seguir, iniciando a partir do freio com presilha da porta 1 (P1) ajustando o cabo e apertando com a chave Allen 2,5 mm.

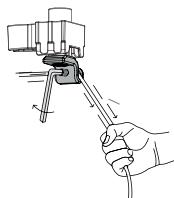

\* A presilha do freio pode ser girada para inverter o lado da instalação. Também tem a possibilidade de fixar o cabo em ambos os lados da presilha, o que facilita sua instalação.

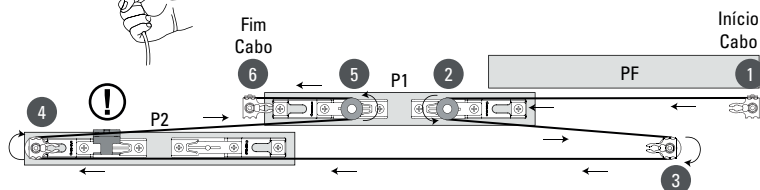

- Depois tensionar o cabo e fixa-lo no outro freio com presilha no final do percurso do cabo.

- Uma vez fixado o cabo aos freios com presilha, fixar o cabo a presilha da placa na porta 2.

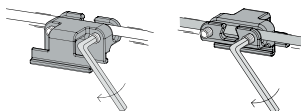
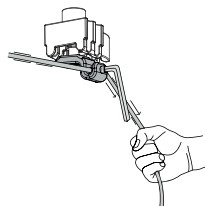

! A presilha pode ser desencaixada da placa e instalada do outro lado para inverter o lado de instalação das portas. Para isso devem-se pressionar as pestanas localizadas na placa como indicado no desenho.

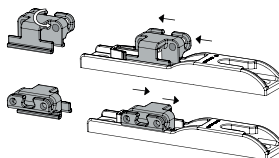
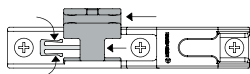



## Acessórios

- 1 SANEFA U21 COM ESPAÇADOR 66x8
- 2 SANEFA U21 COM ESPAÇADOR 120x8
- 3 TAMPA U21 PARA SANEFA 66x8
- 4 TAMPA U21 PARA SANEFA 120x8

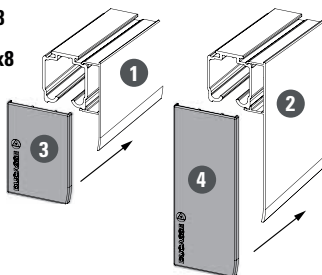

**DUCASSE**   
INDUSTRIAL

[www.ducasseindustrial.com](http://www.ducasseindustrial.com)

LINEA  
SEGMENTA