

TWIN TL VD

- > Instructivo de montaje pg 02
- > Installation Instructions pg 16
- > Instrutivo de montagem pg 30

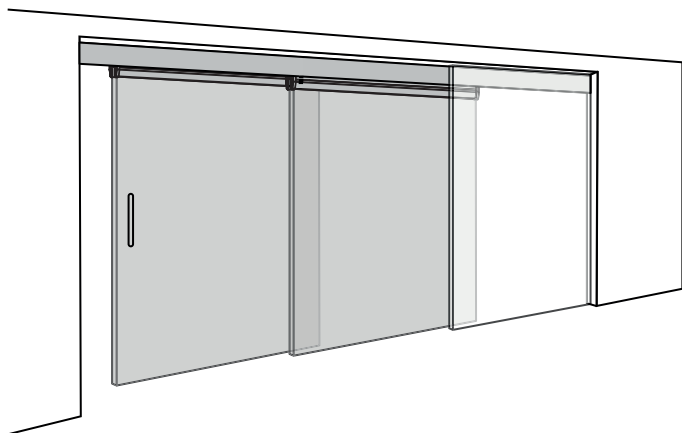

índice

TWIN TL VD es un sistema corredizo sincronizado para puertas de vidrio, de hasta 80 Kg. cada hoja.

El sistema permite que mediante un sólo movimiento se abran ambas puertas sincronizadamente en el mismo sentido.

- 03 Datos generales y dimensionamiento de puertas.
- 04 Detalle de partes y piezas.
- 05 Paso 1: Instalación de riel, carros y frenos.
- 07 Paso 2: Fijación de la guía al suelo.
- 08 Paso 3: Armado de las puertas.
- 09 Paso 4: Fijación de la guía telescópica.
- 10 Paso 5: Montaje de las puertas.
- 11 Paso 6: Fijación de placas e instalación de cenefas.
- 12 Paso 7: Fijación de frenos.
- 13 Paso 8: Regulación de altura.
- 14 Paso 9: Fijación de la piola.
- 15 Accesorios.

mm	Pulgadas	Fracción
1	0.0394	3/64
2	0.0787	5/64
3	0.1181	1/8
4	0.1575	5/32

mm	Pulgadas	Fracción
5	0.1969	13/64
6	0.2362	15/64
7	0.2756	9/32
8	0.3150	5/16

mm	Pulgadas	Fracción
9	0.3543	23/64
10	0.3937	25/64
11	0.4375	7/16
12	0.4688	15/32

***TODAS LAS MEDIDAS ESTÁN INDICADAS EN MILÍMETROS**

Datos generales y dimensionamiento de puertas



CANTIDAD
DE PUERTAS



CAPACIDAD DE CARGA
POR HOJA



PARA PUERTAS
DE VIDRIO



ESPESOR PUERTA
VIDRIO



ZONA
DE PASO



ANCHO PUERTA

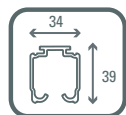

RIEL U21 AL

Para dimensionar las puertas

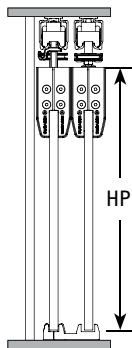
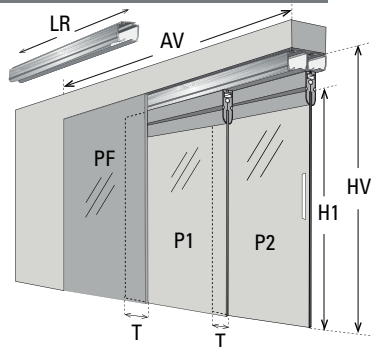

$$\begin{aligned} LR &= 3AP - 100 \\ AP &= (ZP + 2T) / 2 \\ H1 &= HV - 125 \\ APF &\geq (AV + 2T) / 3 \\ HPF &= HV \\ HP &= H1 + 51 \\ T &= 50 \text{ min.} \end{aligned}$$

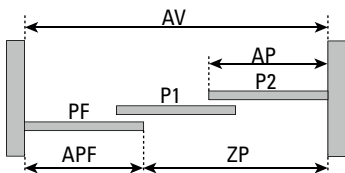

⚠ Utilizar con cristal templado



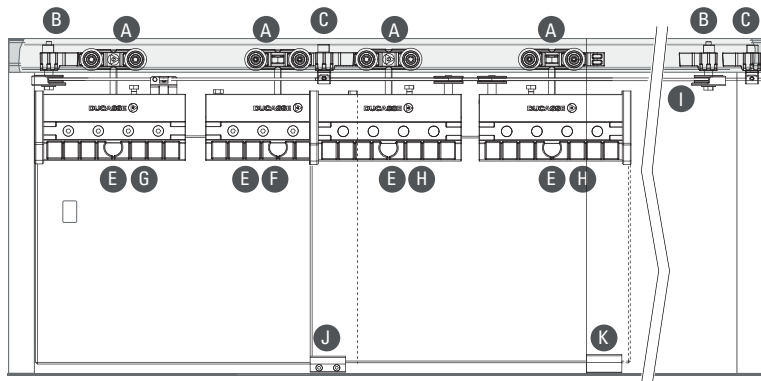

AP = Ancho Puerta | AV = Ancho Vano | H1 = Altura Vidrio | HP = Altura Puerta | HV = Altura Vano
HPF = Altura Paño Fijo | APF = Ancho Paño Fijo | ZP = Zona de Paso | T = Traslape | LR = Largo Riel

Detalle de partes y piezas



TWIN TL VD

A	Carro DN-80		4
B	Frenos Polea Twin		2
C	Frenos Candado		2
D	Perno carro		4
E	Mordaza Pres/Perf		4
F	Placa twin		1
G	Placa candado		1
H	Placa polea		2
I	Piola 13 mt		1
J	Guía telescópica VD		1
K	Guía VD + regulador 8-10		1
L	Tapa mordaza izquierda		4
M	Tapa mordaza derecha		4
N	Llave Segmenta		1
O	Llave allen 2.5 / 3 / 4mm		1

P	Pernos M5 x 20		16
Q	Tarugos N°6		2
R	Tornillos #3.5 x 35		2
S	Kit de limpieza		4

HERRAMIENTAS NECESARIAS

Taladro	
Llave torque	
Plomo	
Destornillador cruz	
Huinchas de medir	

- Cortar los rieles según la fórmula indicada y luego perforar.

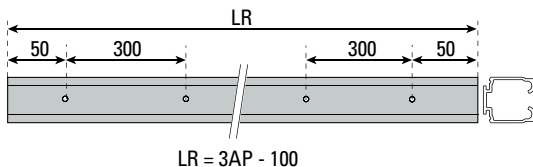

- Armar los conjuntos de carros, introduciendo los pernos a través de las placas y los carros, prestando especial atención a la posición de éstos.

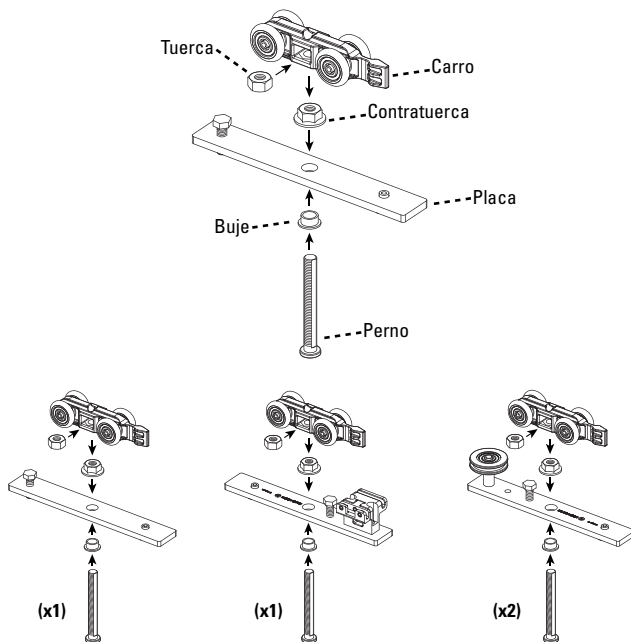

- Introducir carros y frenos candado por ambos extremos del riel 1 (R1), en las posiciones que indica el esquema.
- De igual forma, introducir carros y frenos polea por ambos extremos del riel 2 (R2).

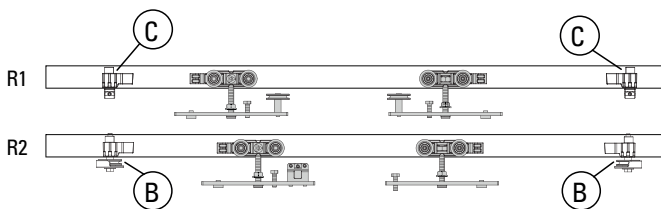
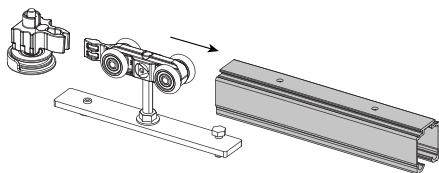

Nota: Riel 1 (R1) para puerta 1 (P1) | Riel 2 (R2) para puerta 2 (P2)

- Fijar los rieles al cielo, tomando en cuenta la distancia indicada en el esquema. (Fijaciones no incluidas).

- Después de fijar, limpiar las pistas de los rieles para evitar posibles residuos.

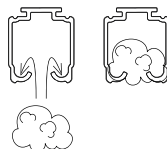
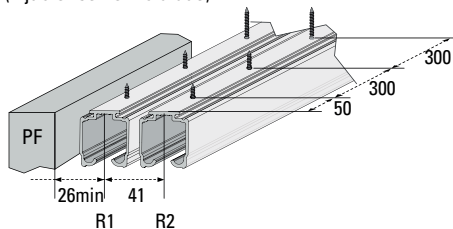

- Aplomar riel 1 (R1) para determinar la posición de la Guía VD

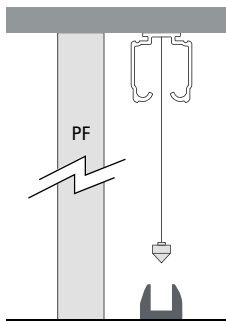

- Posicionar el regulador en la Guía VD, según el espesor de vidrio que se utilice.

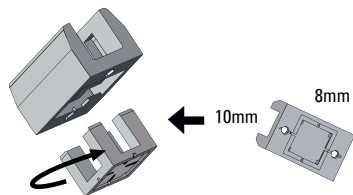

- Fijar la guía al suelo al tope del paño fijo, tal como lo indica el esquema, utilizando los tarugos n°6 y luego los tornillos #3.5x35.

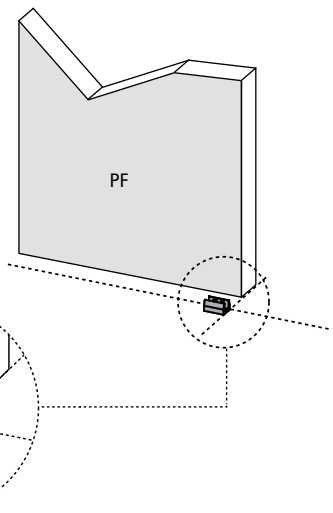
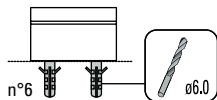

Paso 3

OPCIÓN (A): Mordazas perforadas / OPCIÓN (B): Mordazas a presión

①

- (A) Mecanizar el vidrio según las indicaciones del esquema.

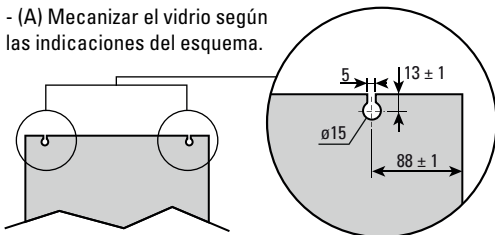

(B) Limpiar el cristal en la zona de instalación de la mordaza con el Kit de limpieza incluido.



②

- (A) y (B) Colocar el distanciador en la posición 8-10mm.

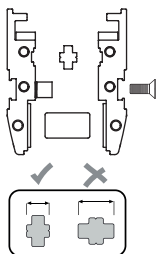

③

- (A) y (B) Posicionar la mordaza en el cristal, a 6mm del borde.
- (A) Colocar buje en el cristal.

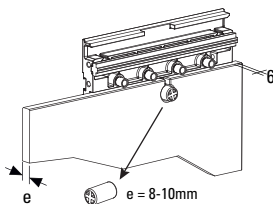

④

- (A) y (B) Colocar la otra parte de la mordaza y apretar los pernos con llave Allen 4mm.

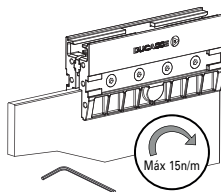

⑤

- (A) y (B) Colocar adhesivos en los extremos.

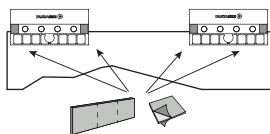

*** Los topes de las mordazas deben quedar posicionados para lados opuestos.

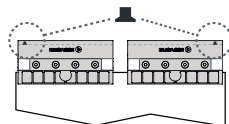

OPCIÓN (A)

- * Recomendada para cristales sobre 50kg.
- * Contemplar perforaciones de tiradores.
- * Recomendada para condiciones de humedad.

- Configurar la guía telescópica según el espesor de la puerta, girando el regulador tal como se indica en el esquema.

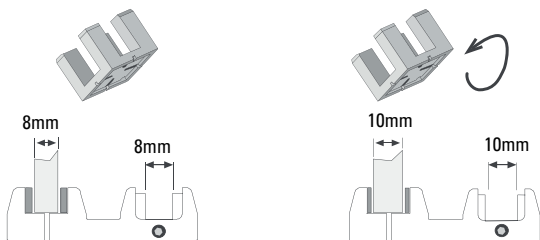

- Situar guía telescópica en el lado interior de la puerta 1 (P1), al tope del vidrio.
Fijar la guía a la puerta ajustando los prisioneros con la llave Allen 3mm y ajustar el prisionero lateral con la llave Allen 2mm.

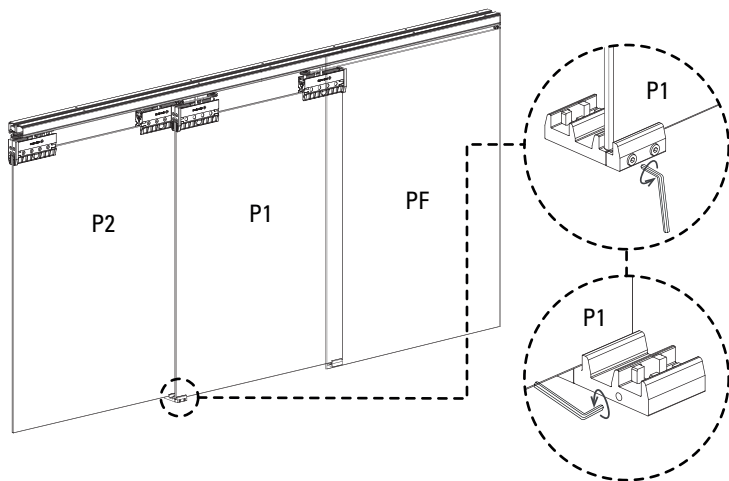

Paso 5

- Montar la puerta 1 (P1) sobre la guía VD, cuidando de no dañar la guía telescópica, e introducir las placas en las mordazas.
- Montar con precaución la puerta 2 (P2) sobre la guía telescópica e introducir las placas en las mordazas, cuidando que en la puerta 2 (P2) las poleas de las placas queden hacia el interior de la puerta.

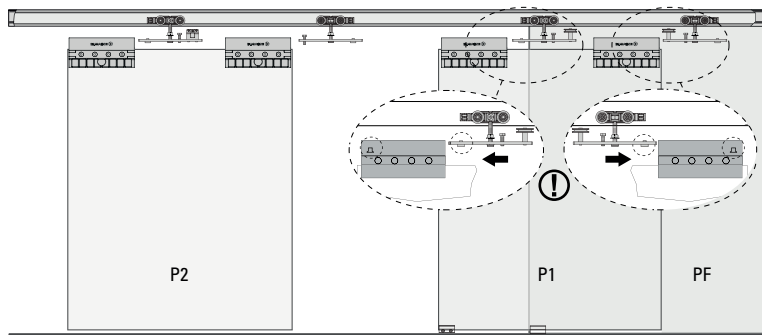
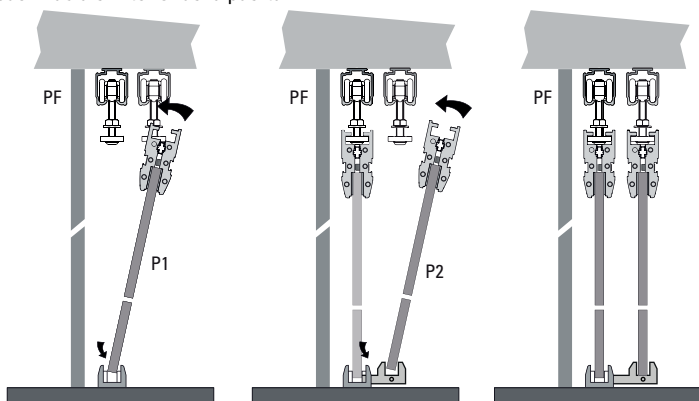

- Con ayuda de la llave Segmenta, fijar las placas de los carros a las mordazas, ajustando el perno superior, tal como se indica.

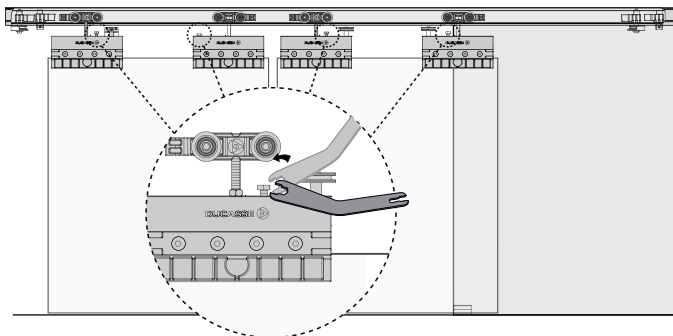

- Levanta la contratuerca del perno, clipear la cenefa en las mordazas de la puerta, y luego fijar las tapas derecha e izquierda por ambos costados, con los pernos M5 x 20 y la llave Allen 3mm.

- Luego, apretar la contratuerca contra la cenefa.

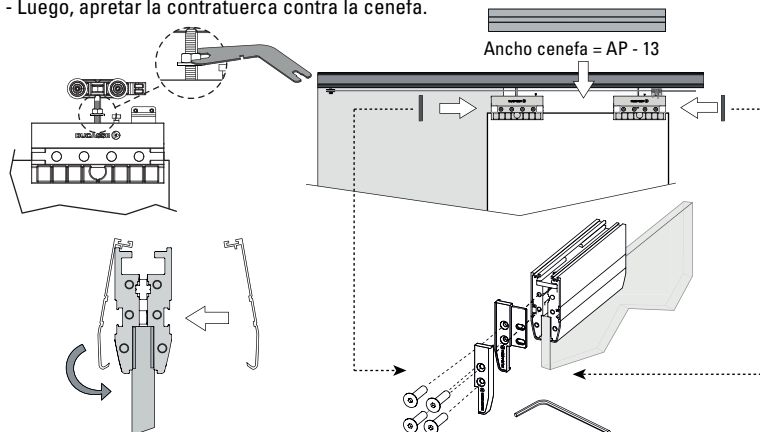

Paso 7

- Llevar las puertas ya montadas a su posición cerrada para poder fijar los frenos. Para ello, es necesario moverlos hasta encajarlos con los carros y fijarlos en esa posición.

- El freno candado (C) se fija en la puerta 1 (P1) con destornillador y el freno polea (B) se fija en la puerta 2 (P2) con la llave Segmenta

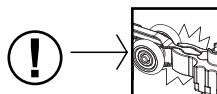
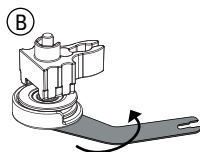
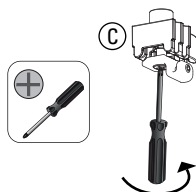
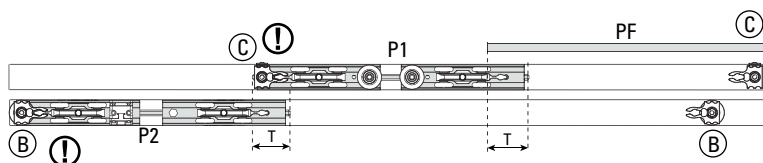

* Para asegurarse de que las piezas queden en la posición correcta, es necesario encajar los frenos al carro.

- Luego, para fijar los frenos restantes es necesario llevar las puertas a su posición abierta, mover los frenos hasta encajarlos con los carros y fijarlos en esa posición.

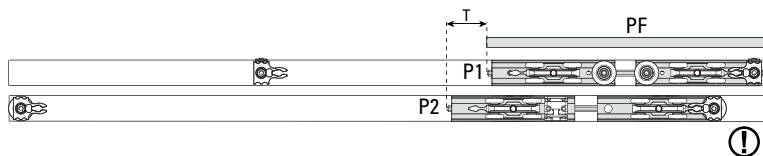

* Para asegurarse de que las piezas queden en la posición correcta, es necesario que las poleas queden libres hacia el centro del vano.



- Regular la altura de los vidrios, ajustando el perno del carro con la llave Segmenta.

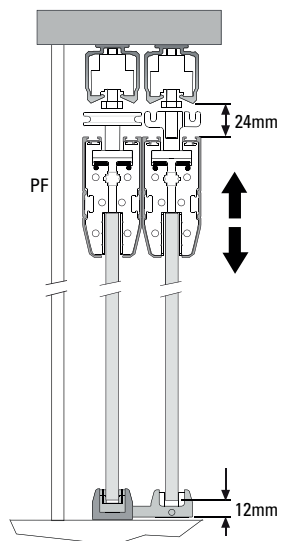
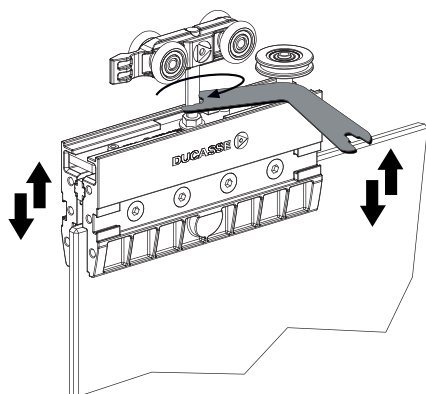

Paso 9

- Con las puertas cerradas, colocar la piola siguiendo los pasos y el recorrido indicado por el esquema, partiendo por ajustarla en el freno candado de la puerta 1 (P1) con llave Allen 2.5mm.

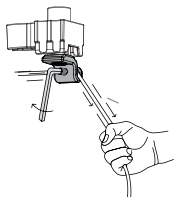

* El candado del freno tiene la posibilidad de girarse en caso de tener instalaciones inversas. También ofrece la posibilidad de fijar la piola en ambas caras del candado, lo que facilita la instalación.

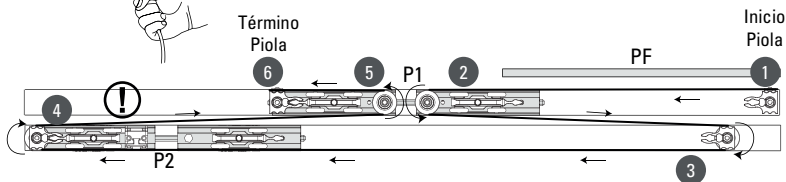

- Después, tensar la piola y fijarla en el otro freno candado.

- Una vez fijados los frenos candados, fijar la piola al candado de la placa por el lado del paño fijo.

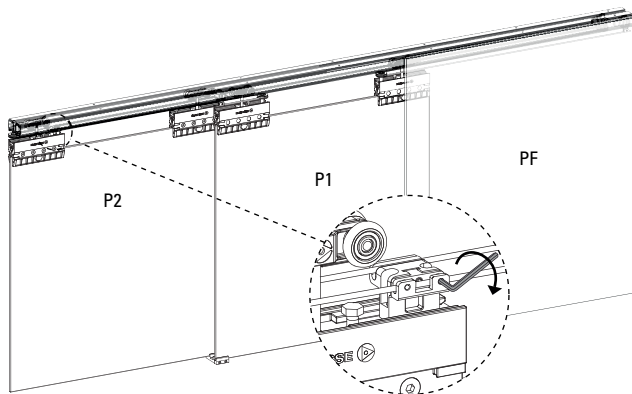
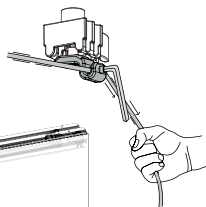

Accesorios

1 CENEFA U-21 66x8

2 CENEFA U-21 120x8

3 TAPA U-21 CENEFA 66x8

4 TAPA U-21 CENEFA 120x8

5 TAPA MORDAZA ZK

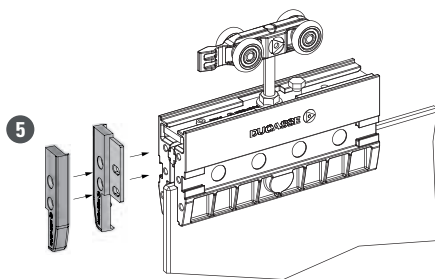
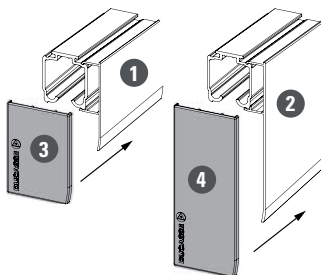

index

TWIN TL VD is a synchronized sliding system for glass doors of up to 80 Kg. each sheet.

The system allows the synchronized, same direction opening of both doors with only a single movement.

- 17 General data and door sizing.
- 18 Detail of parts and pieces.
- 19 Step 1: Track, carrier and stopper installation.
- 21 Step 2: Set-up of the guide to the floor.
- 22 Step 3: Doors mounting.
- 23 Step 4: Set-up of the telescopic guide.
- 24 Step 5: Doors mounting.
- 25 Step 6: Plates fixing and fascias Set-up.
- 26 Step 7: Stoppers Set-up.
- 27 Step 8: Height regulation.
- 28 Step 9: Cable Set-up.
- 29 Accessories.

mm	Inches	Fraction
1	0.0394	3/64
2	0.0787	5/64
3	0.1181	1/8
4	0.1575	5/32

mm	Inches	Fraction
5	0.1969	13/64
6	0.2362	15/64
7	0.2756	9/32
8	0.3150	5/16

mm	Inches	Fraction
9	0.3543	23/64
10	0.3937	25/64
11	0.4375	7/16
12	0.4688	15/32

***ALL MEASUREMENTS ARE EXPRESSED IN MILLIMETERS**

General data and door sizing



NUMBER OF DOORS



LOAD CAPACITY PER SHEET



FOR GLASS DOORS



GLASS DOORS THICKNESS



TRANSIT AREA



DOOR WIDTH

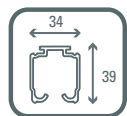

TRACK U21 AL

Doors sizing

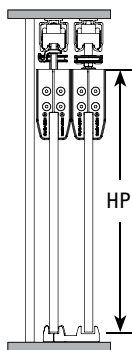
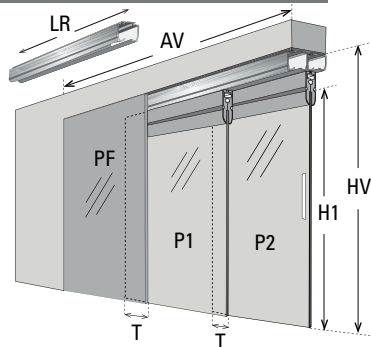

$$LR = 3AP - 100$$

$$AP = (ZP + 2T) / 2$$

$$H1 = HV - 125$$

$$APF \geq (AV + 2T) / 3$$

$$HPF = HV$$

$$HP = H1 + 51$$

$$T = 50 \text{ min.}$$

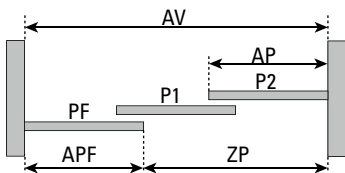







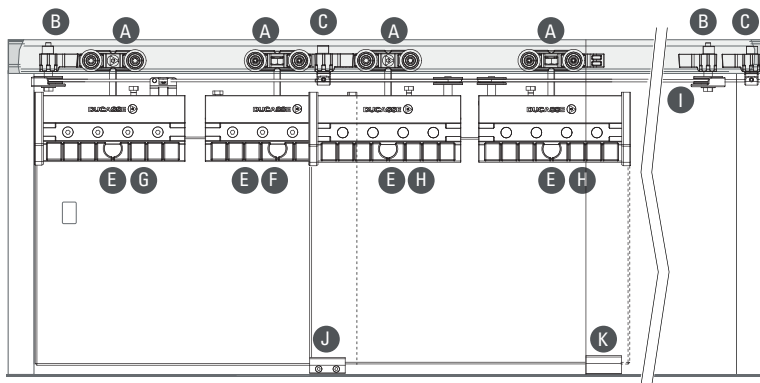







! Use with tempered glass





AP = Door Width | AV = Opening Width | H1 = Glass Height | HP = Door Height | HV = Opening Height
HPF = Fixed Panel Height | APF = Fixed Panel Width | ZP = Transit Area | T = Overlap | LR = Track Length

Detail of parts and pieces







TWIN TL VD

A	DN 80 Carriers		4
B	Twin pulley stoppers		2
C	Lock stoppers		2
D	Carrier Bolt		4
E	Superior clamp		4
F	Twin Plate		1
G	Lock Plate		1
H	Pulley Plate		2
I	15 mts of cable		1
J	Telescopic guide VD		1
K	Floor guide VD + regulator 8-10		1
L	Clamp end left cap		4
M	Clamp end right cap		4
N	Segmenta key 1		1
O	Allen key 2.5 / 3 / 4mm		1

P	Bolts M5 x 20		16
Q	Dowels n°6		2
R	Screws #3.5 x 35		2
S	Cleaning Kit		4

NECESSARY TOOLS

Drill	
Torque wrench	
Plumb line	
Phillips screwdriver	
Measuring tape	

Track, carrier and stopper installation

step 1

- Cut the tracks according to the following formula and then, drill.

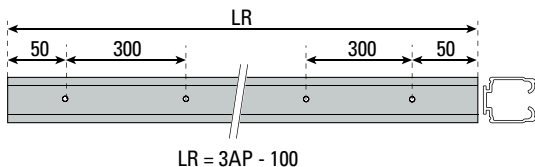

- Set up the carrier sets, inserting the carrier bolts through the plates and carriers, paying special attention to their position.

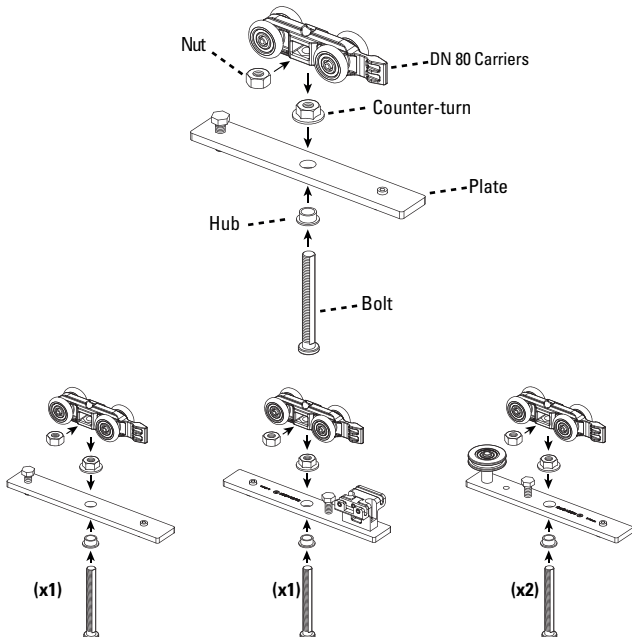

- Insert carriers and lock stoppers in both ends of the track 1 (R1), as shown in the diagram.
- Similarly, insert the carriers and pulley stoppers at both ends of the track 2 (R2).

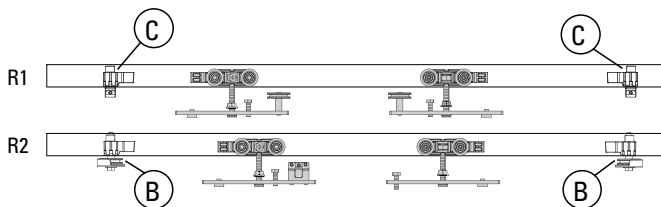
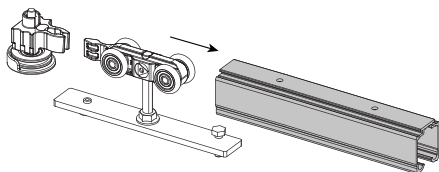

Note: Track 1 (R1) for port 1 (P1) | Track 2 (R2) for port 2 (P2)

- Fix the tracks to the ceiling. Take into consideration the distance which is shown in the drawing. (Fixtures not included).

- After fixing, clean the track grooves to avoid possible leftover residues.

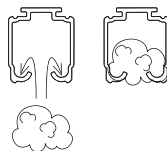
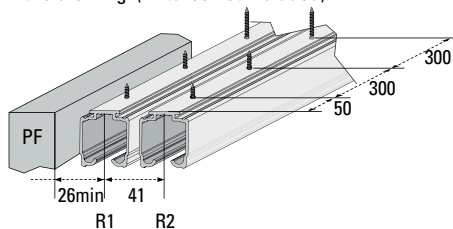

- Plumb track 1 (R1) to determine the Floor guide VD position.

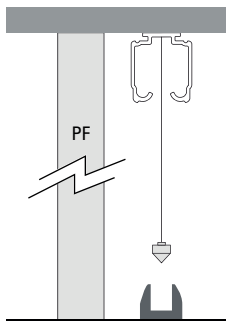

- Position the regulator in the Floor guide VD, according with the glass width to be used.

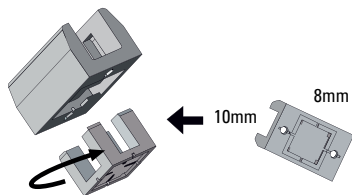

- Fix the guide to the floor at the bound of the fixed panel, as shown in the diagram, using dowels n°6 and then screws 3.5x35

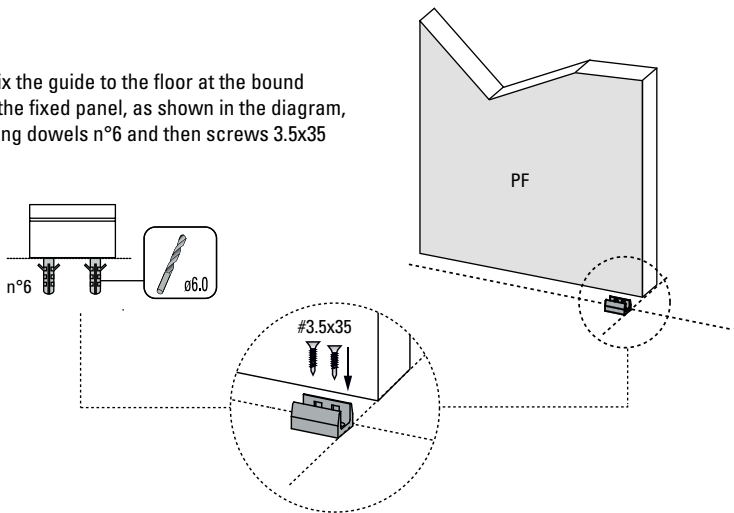

step 3

OPTION (A): Perforated clamps / OPTION (B): Compression clamps

①

- (A) Set up the glass according to the indications on the diagram.

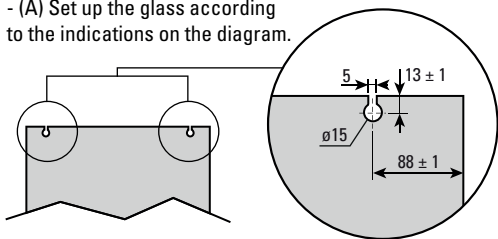

(B) Clean the glass in the clamp installation area using the cleaning kit included.



②

- (A) and (B) Place the spacer in the 8-10mm position

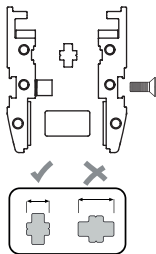

③

- (A) and (B) Place the clamp in the crystal, 6mm from the edge.
- (A) Place the metal hub in the crystal.

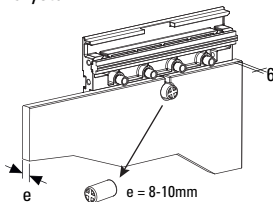

④

- (A) and (B) Place the other part of the clamp and tighten the bolts with the 4mm Allen key.

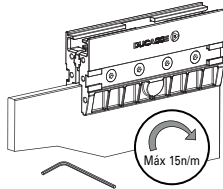

⑤

- (A) and (B) Place the adhesives on the edges.

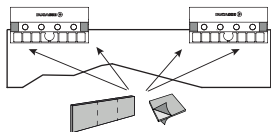

*** Clamps stoppers must be positioned at opposite sides.

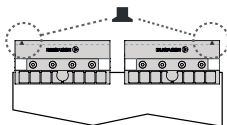

OPTION (A)

- * Recommended for crystals over 50 kg.
- * Consider perforations for the door handles.
- * Recommended for high humidity conditions.

Set-up of the telescopic guide

step 4

- Configure telescopic guide according to the door thickness, adjusting the floor guide insert as indicated in the diagram.

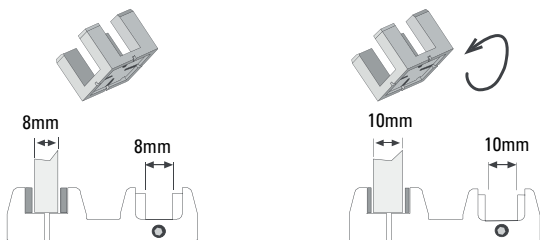

- Position the telescopic guide on the internal side of Door 1 (P1), to the end of the glass. Fix the guide onto the door adjusting the prisoners with the 3mm Allen Key and adjust the lateral prisoner with the 2mm Allen Key.

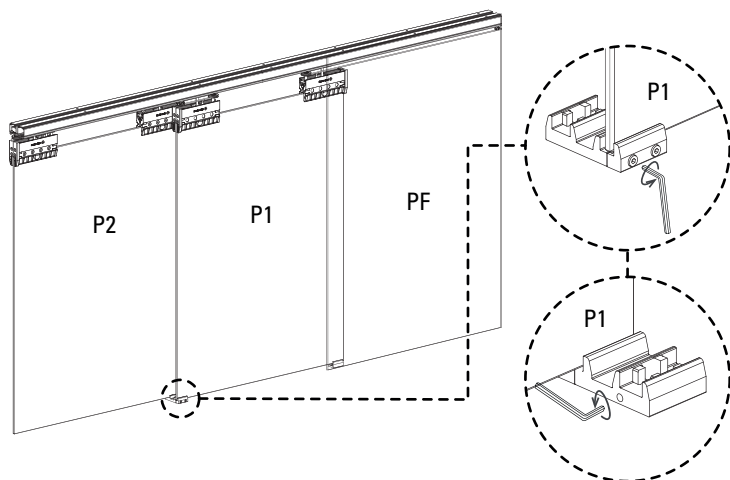

step 5

- Mount Door 1 (P1) on floor guide VD, making sure the telescopic guide is not damaged, and introduce the plates in the clamps.
- Carefully mount Door 2 (P2) on the telescopic guide and introduce the plates in the clamps, making sure that on Door 2 (P2) the plate pulleys are left towards the interior of the door.

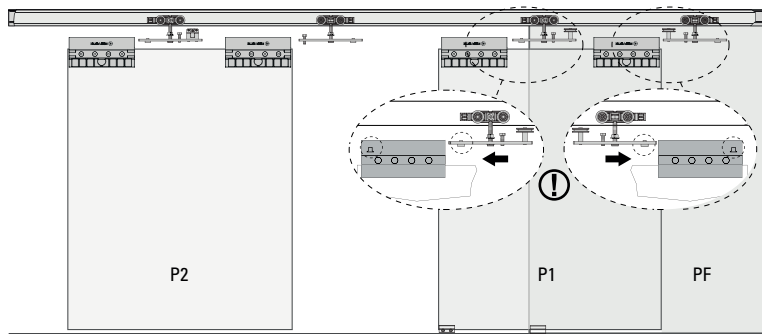
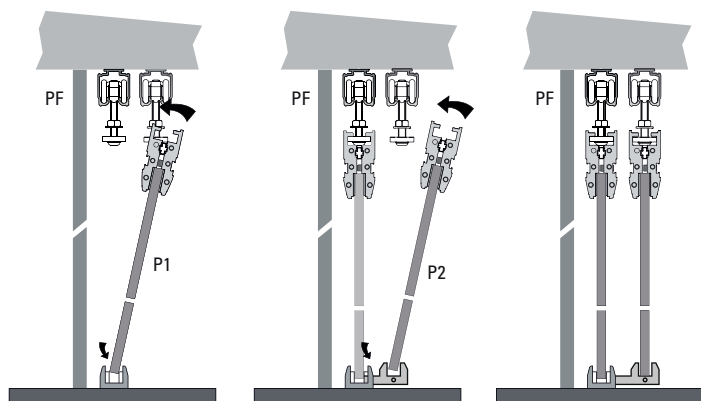

- With the help of the Segmenta key, fix the carrier plates to the clamps, adjusting the upper bolt, as shown.

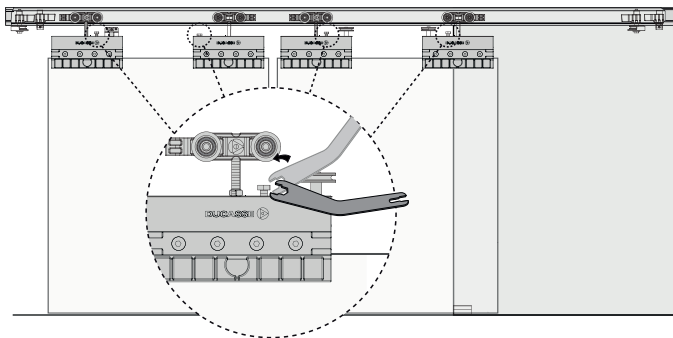

- Clip the fascia in the door clamps and then fix the right and left end caps on both sides, with M5 x 20 bolts and the 3mm Allen key.

- Then, reverse the previous step, lowering again the counterturn in the same way.

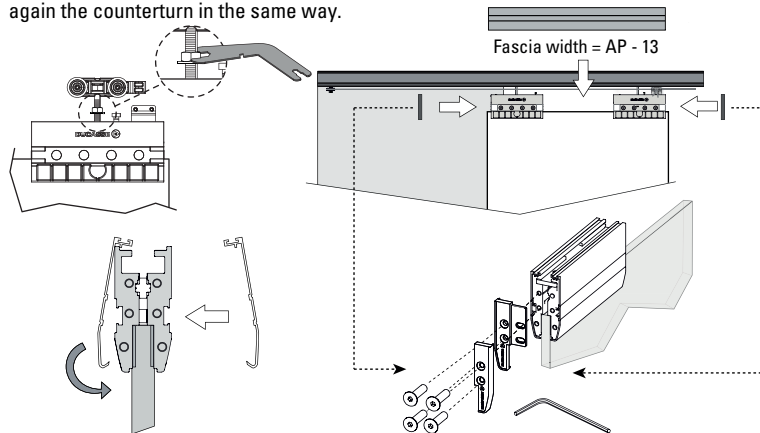

step 7

- Keep mounted doors in its closed position to fix the stoppers. To do this, you need to move them until they fit with the carriers and then, fix them in that position.

- The lock stopper (C) is set on door 1 (P1) with a screwdriver and the pulley stopper (B) must be fixed on the door 2 (P2) using Segmenta key.

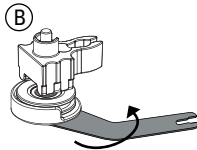
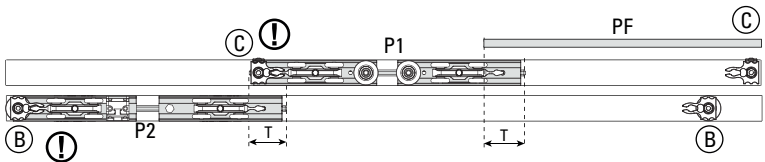

* To make sure the pieces are left in the right position, it is necessary to fit the stoppers on the carrier.

- Then, to fix the remaining stoppers it is necessary to bring the doors to a open position, move the stoppers until fitting them with the carriers and fix them in that position.

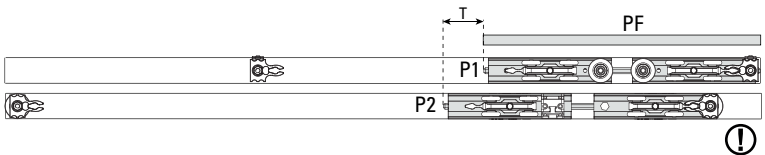

* To make sure the pieces are left in the right position, it is necessary that the pulley is free towards the center of the rail.



Height adjustment

step 8

- Regulate the height of the glasses, adjusting the carrier bolt with the Segmenta key.

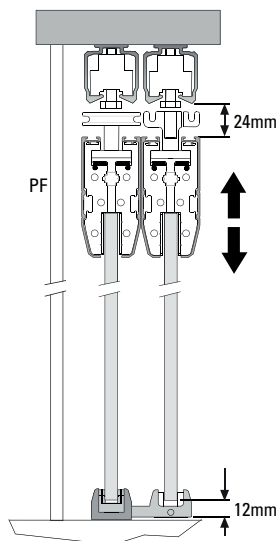
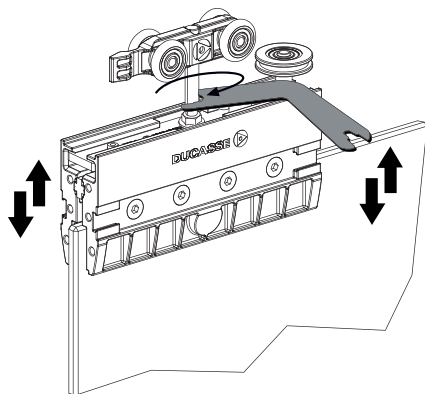

step 9

- With the doors closed, place the cable following the steps and the path indicated in the diagram. Start the process by adjusting it on the lock stopper of the door 1 (P1) using a 2.5mm Allen key.

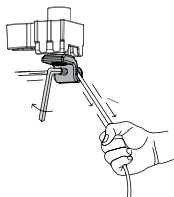

* The lock stopper has the ability to turn in case of inverse facilities. It also offers the possibility to set the cable on both sides of the lock, which makes installation easy.

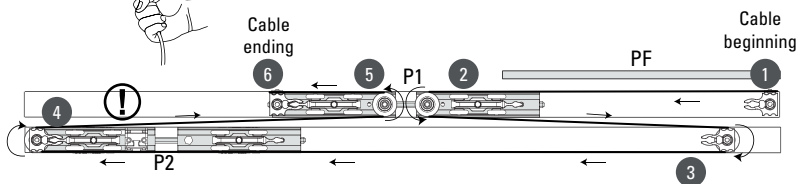

- Then, tighten the cable and set it on the other lock stopper.

- Once the lock stoppers are fixed, fix the cable to the lock of the base.

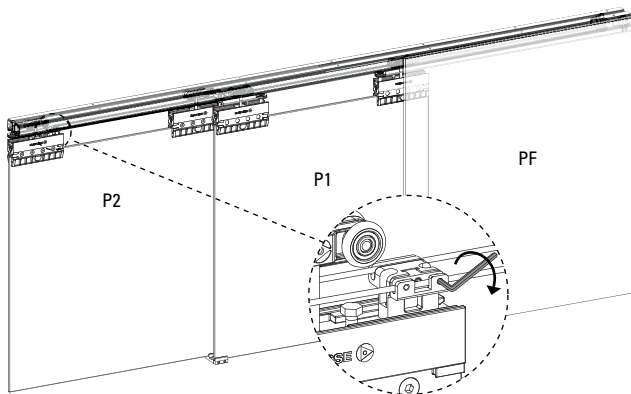
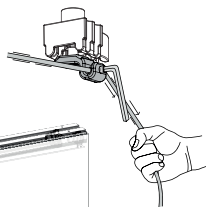

Accessories

1 FASCIA U-21 66x8

2 FASCIA U-21 120x8

3 END CAP FASCIA U-21 66x8

4 END CAP FASCIA U-21 120x8

5 ZAMAK END CAPS

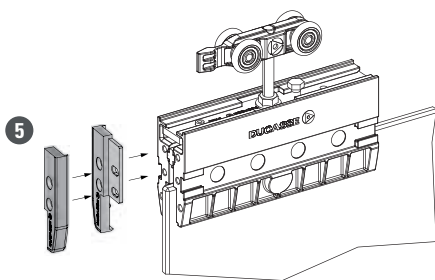
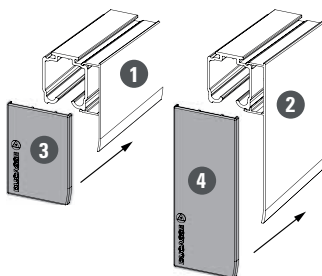

índice

TWIN TL VD é um sistema correção sincronizado para portas de vidro, de até 80kg cada folha

O sistema permite que com um só movimento se abram ambas as portas sincronizadamente na mesmo sentido.

- 31 Dados gerais e dimensionamento das portas.
- 32 Detalhes de partes e peças.
- 33 Passo 1: Instalação de trilho, carros e freios.
- 35 Passo 2: Fixação da guia ao chão.
- 36 Passo 3: Armação das portas.
- 37 Passo 4: Fixação da guia telescópica.
- 38 Passo 5: Montagem das portas.
- 39 Passo 6: Fixação das placas e instalação das sanefas.
- 40 Passo 7: Fixação de freios.
- 41 Passo 8: Regulagem de altura.
- 42 Passo 9: Fixação do cabo.
- 43 Acessórios.

mm	Polegadas	Fração
1	0.0394	3/64
2	0.0787	5/64
3	0.1181	1/8
4	0.1575	5/32

mm	Polegadas	Fração
5	0.1969	13/64
6	0.2362	15/64
7	0.2756	9/32
8	0.3150	5/16

mm	Polegadas	Fração
9	0.3543	23/64
10	0.3937	25/64
11	0.4375	7/16
12	0.4688	15/32

***TODAS AS MEDIDAS ESTÃO INDICADAS EM MILÍMETROS**

Dados gerais e dimensionamento das portas



QUANTIDADE
DE PORTAS



CAPACIDADE DE
CARGA POR PORTA



PARA PORTAS
DE VIDRO



ESPESSURA PORTA
VIDRO



VÃO DE PASSAGEM



LARGURA DA
PORTA

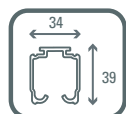

TRILHO U21
PARA SANEFA

Como dimensionar as portas

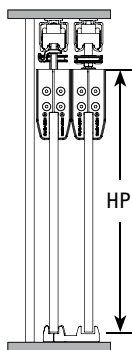
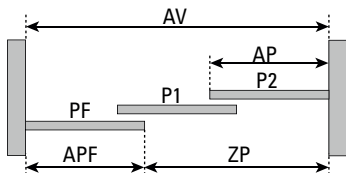
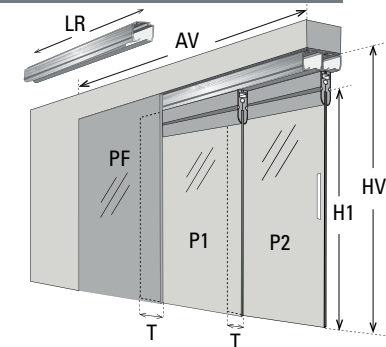

$$\begin{aligned} LR &= 3AP - 100 \\ AP &= (ZP+2T)/2 \\ H1 &= HV - 125 \\ APF &\geq (AV+2T)/3 \\ HPF &= HV \\ HP &= H1 + 51 \\ T &= 50 \text{ min.} \end{aligned}$$







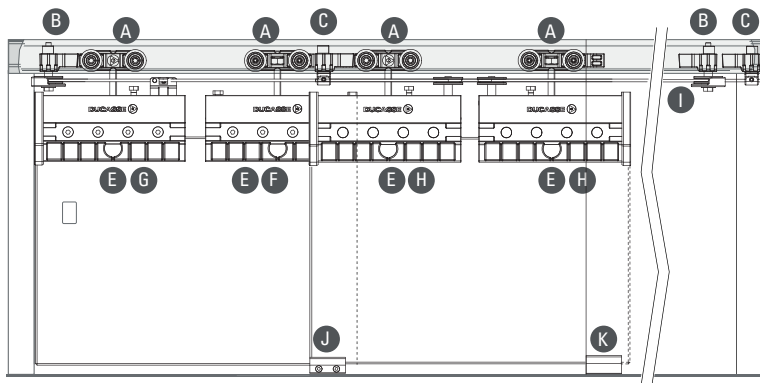







⚠ Usar com vidro temperado





**AP = Largura Porta | AV = Largura Vão | H1 = Altura Vidro | HP = Altura Porta | HV = Altura Vão
HPF = Altura Pannel Fixo | APF = Largura Pannel Fixo | ZP = Zona de Passagem
LR = Comprimento Trilho | T = Sobreposição**

Detalhes de partes e peças





TWIN TL VD

A	Carro DN 80		4
B	Freio roldana		2
C	Freio cadeado		2
D	Parafuso carro		4
E	Mordaça superior		4
F	Placa Twin		1
G	Placa candado		1
H	Placa Polia		2
I	15 mts cabo		1
J	Guia Telescopica VD		1
K	Guia VD + espaçador 8-10		1
L	Tampa mordaça esquerda		4
M	Tampa mordaça direita		4
N	Chave Segmenta		1
O	Chave Allen 2.5 / 3 / 4mm		1

P	Parafusos M5 x 20		16
Q	Buchas nº6		2
R	Parafusos #3.5 x 35		2
S	Kit de limpeza		4

NECESSARY TOOLS

Furadeira	
Torquimetro	
Prumo	
Chave Phillips	
Trena	

- Cortar os trilhos conforme a fórmula indicada e perfurar.

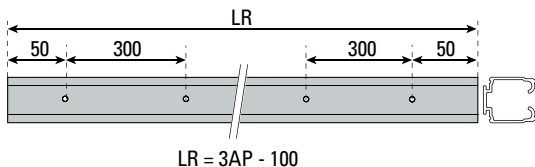

- Armar os conjuntos de carros, introduzindo os parafusos através das placas e dos carros, prestando atenção especial na posição dos mesmos.

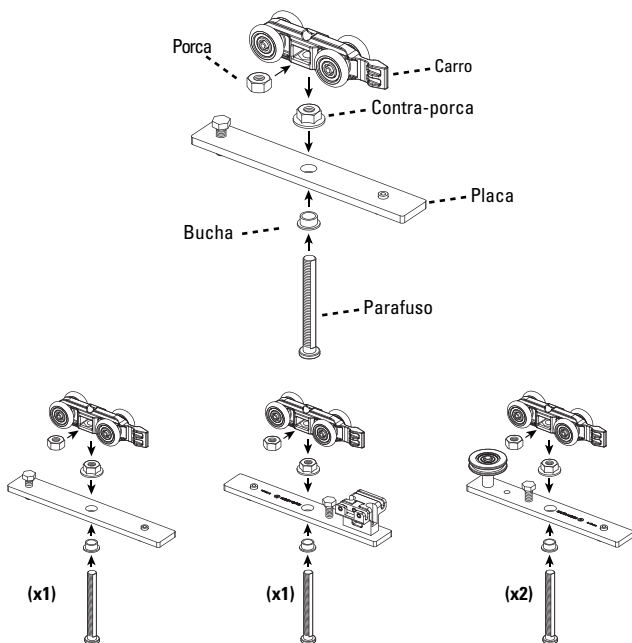

- Introduzir carros Twin e freios cadeado por ambos extremos do trilho 1 (R1), tal como se indica no esquema.
- Da mesma forma, introduzir carros Twin e freios roldana por ambos extremos do trilho 2 (R2).

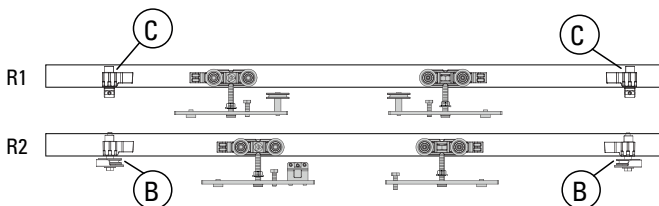
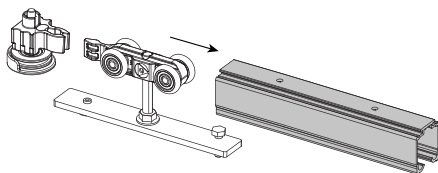

Trilho 1 (R1) para porta 1 (P1) | Trilho 2 (R2) para porta 2 (P2)

- Fixar o trilho superior, considerando a distância indicada no esquema. (Fixações não incluídas).

- Depois de fixar, limpar as pistas do trilho para evitar possíveis resíduos.

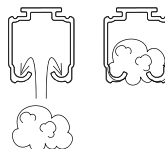
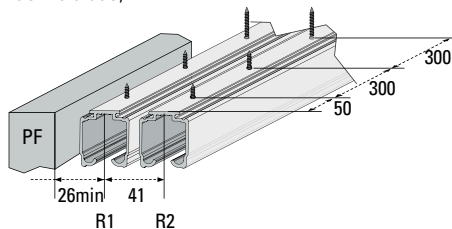

Fixação da guia ao chão

passo 2

- Plumb track 1 (R1) to determine the Floor guide VD position.

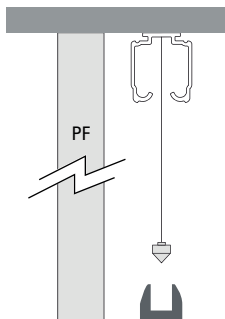

- Posicionar o regulador na guia VD, de acordo com a espessura do vidro utilizado.

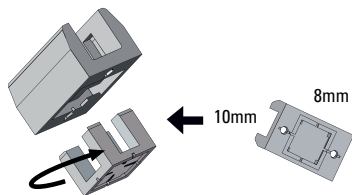

Fixar a guia no piso alinhando com o painel fixo, como indica o desenho utilizando as buchas N°6 e após os parafusos 3,5x35.

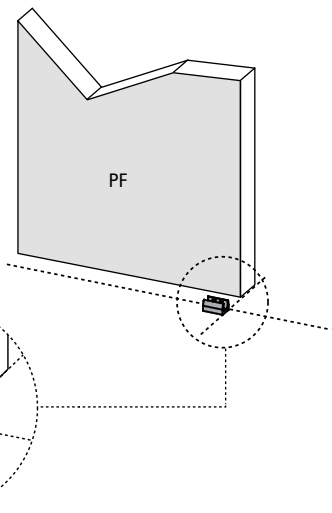
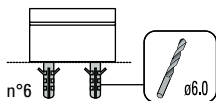

passo 3

OPÇÃO (A): Mordças perfuradas / OPÇÃO (B): Mordças à pressão

①

- (A) Usinar o vidro conforme as indicações do desenho

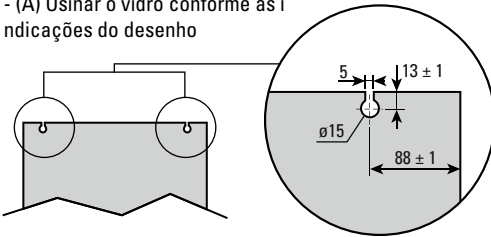

(B) Limpar o vidro na zona de instalação da mordça com o kit de limpeza incluído.

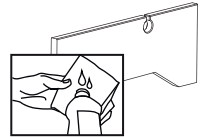

②

- (A) e (B) colocar o distanciador na posição 8-10mm.

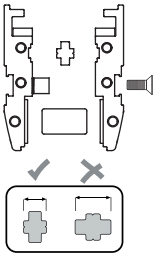

③

- (A) e (B) Posicionar a mordça no vidro (B) a 6mm da borda.
- (A) Colocar a bucha no vidro.

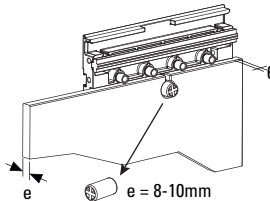

④

- (A) e (B) Colocar a outra parte da mordça e apertar os parafusos com a chave Allen 4mm.

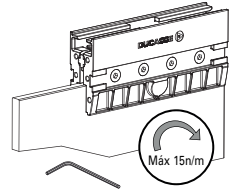

⑤

- (A) e (B) Colocar os adesivos nos extremos da mordça.

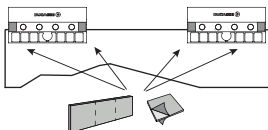

*** Os topes das mordças devem ficar posicionadas para lados opostos

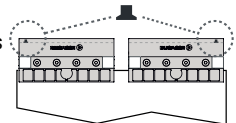

OPÇÃO (A)

- * Recomendada para portas acima de 50kg.
- * Prever as furações para puxadores.
- * Recomendada para locais com umidade elevada.

- Configurar a guia telescópica de acordo com a espessura do vidro, girando o regulador como se indica no desenho.

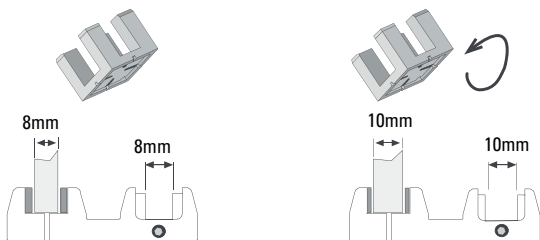

- Posicionar a guia telescópica no lado interno da porta 1 (P1), no topo do vidro. Fixar a guia na porta ajustando os prisioneiros com a chave Allen 3mm e ajustar o prisioneiro lateral com a chave Allen 2mm.

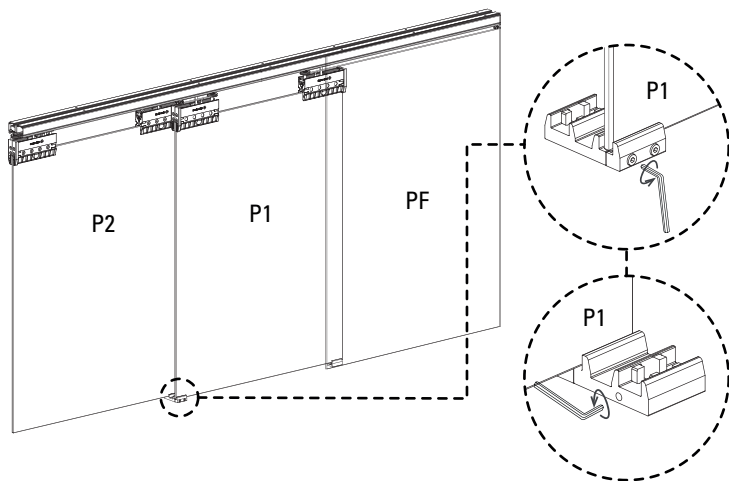

passo 5

- Montar a porta 1 (P1) sobre a guía VD, cuidando de não danificar a guía telescópica, e introduzir as placas nas mordças.
- Montar com cuidado a porta 2 (P2) sobre a guía telescópica e introduzir as placas nas mordças, cuidando para que a porta 2 (P2) fique com as polias das placas para o lado interno da porta.

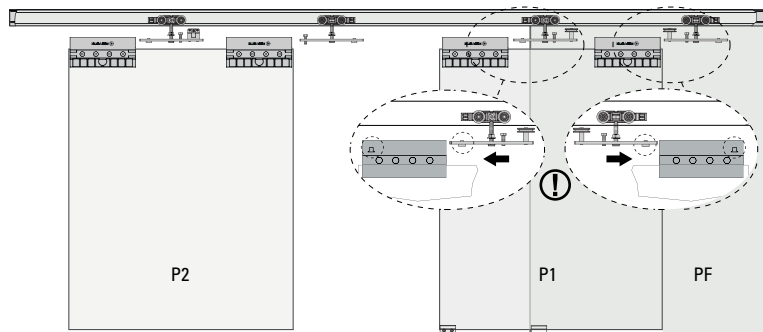
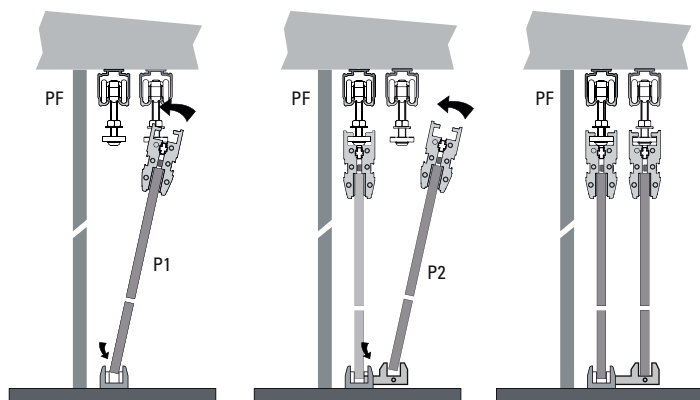

- Com a ajuda da chave Segmenta, fixar as placas dos carros nas mordaças, ajustando o parafuso superior, como se indica.

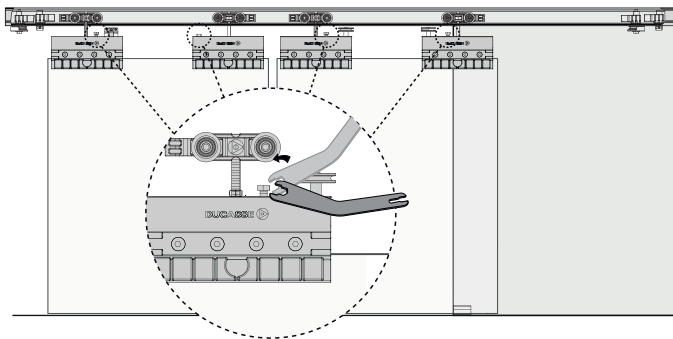

- Clipar as sanefas nas mordaças da porta, e após fixar as tampas direitas e esquerdas por ambos os lados, com parafusos M5 x 20 e a chave Allen 3mm.

- Depois, reverter o passo anterior, voltando a baixar a contra-porca do mesmo modo.

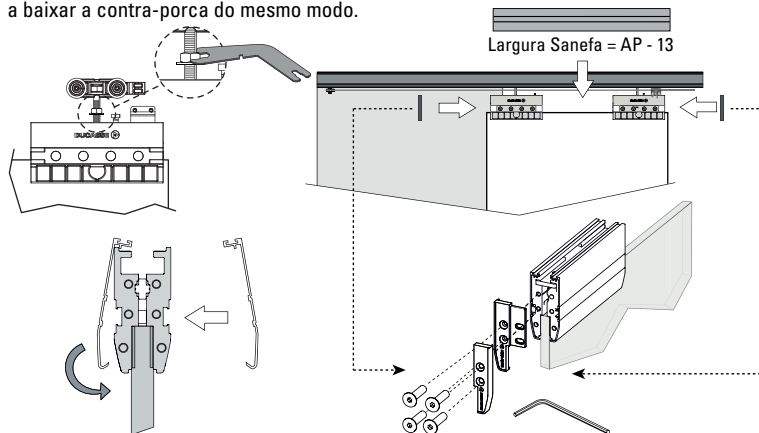

passo 7

- Levantar as portas já montadas à sua posição fechada para poder fixar os freios. Para isso, é necessário movê-los até encaixá-los com os carros e fixá-los nesta posição.

- O freio cadeado (C) é fixado na porta 1 (P1) com chave de fenda e o freio roldana (B) é fixado na porta 2 (P2) com a chave Segmenta.

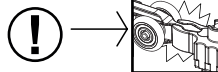
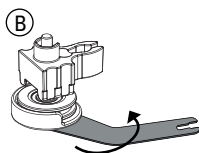
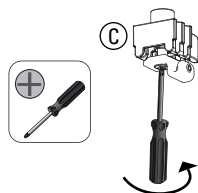
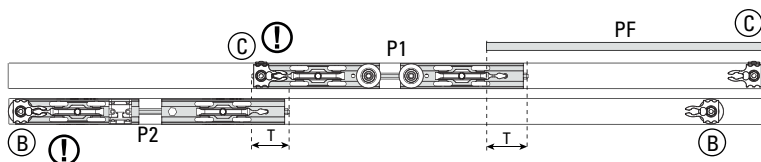

* Para assegurar-se que as peças estejam na posição correta, é necessário encaixar os freios nos carros.

- Depois, para fixar os freios restantes é necessário levar as portas à sua posição aberta, mover os freios até encaixá-los com os carros e fixá-los nessa posição.

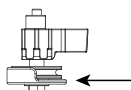
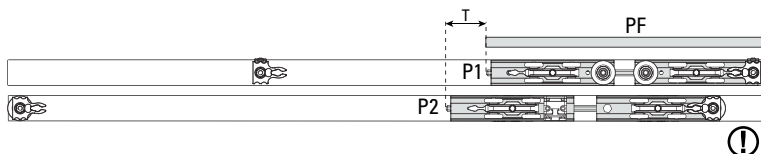

* Para garantir que as peças fiquem na posição correta, é necessário que as polias fiquem livres e no centro do trilho.

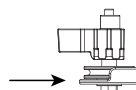

- Regular a altura dos vidros, ajustando o parafuso do carro com a chave Segmenta.

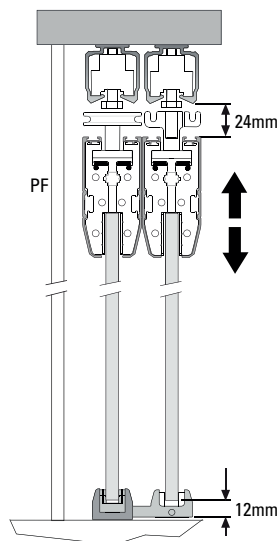
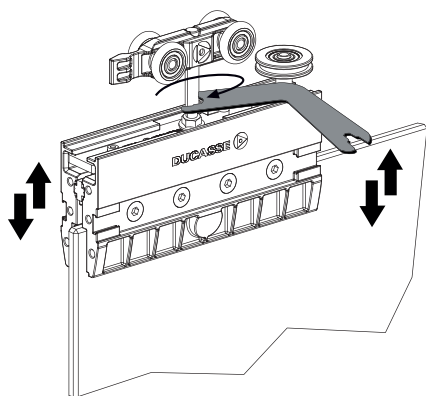

passo 9

- Com as portas fechadas, colocar o cabo seguindo os passos e o percurso indicado pelo esquema, começando por ajustá-lo no freio cadeado da porta 1 (P1) com chave Allen 2.5mm

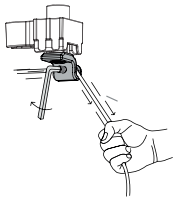

* A presilha do freio pode ser girada para inverter o lado da instalação. Também tem a possibilidade de fixar o cabo em ambos os lados da presilha, o que facilita sua instalação.

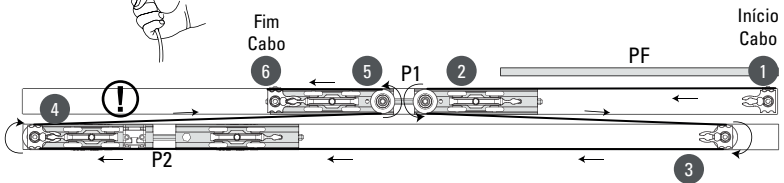

- Depois tensionar o cabo e fixa-lo no outro freio com presilha no final do percurso do cabo.

- Uma vez fixados os freios candados, fixar a corda ao candado voltado para o lado do painel fixo.

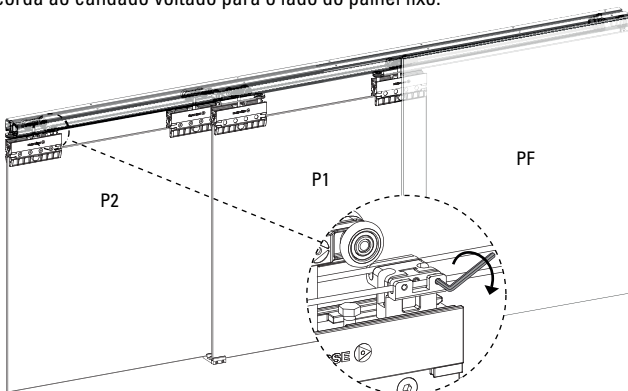
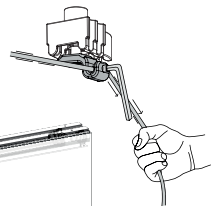

Acessórios

1 SANEFA U-21 66x8

2 SANEFA U-21 120x8

3 TAMPA U-21 SANEFA 66x8

4 TAMPA U-21 SANEFA 120x8

5 TAMPA MORDAÇA ZK

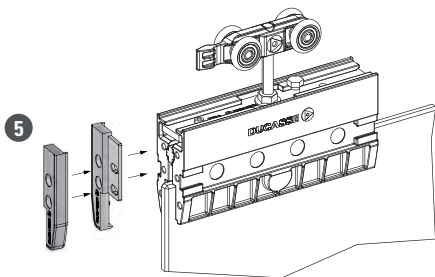
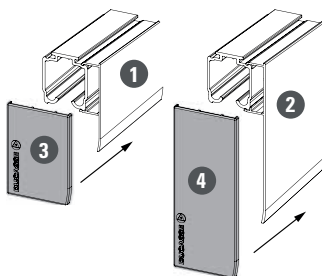

DUCASSE 
INDUSTRIAL

www.ducasseindustrial.com

LINEA
SEGMENTA