

CD 50 - S

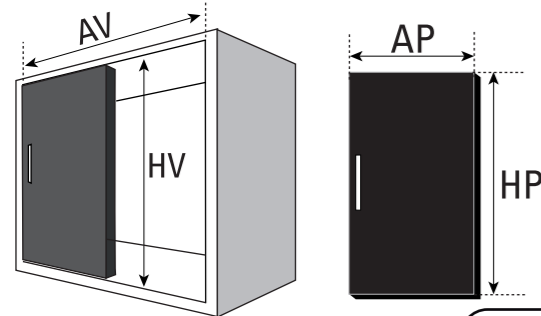
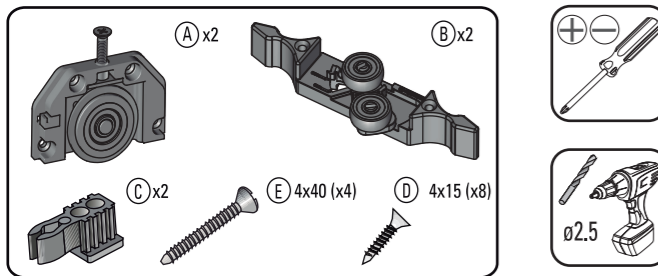
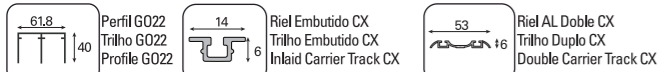
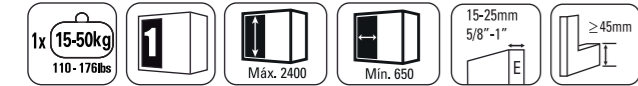

AV = Ancho de vano
AP = Ancho de puerta
HP = Altura de puerta
HV = Altura de vano

Todas las medidas expresadas en milímetros
Todas as medidas estão em milímetros.
All measurements in millimeters.

mm	Decimal inches	Aprox Fraction	mm	Decimal inches	Aprox Fraction
1	0.0394	3/64	6	0.2362	15/64
2	0.0787	5/64	7	0.2756	9/32
3	0.1181	1/8	8	0.3150	5/16
4	0.1575	5/32	9	0.3543	23/64
5	0.1969	13/64	10	0.3937	25/64

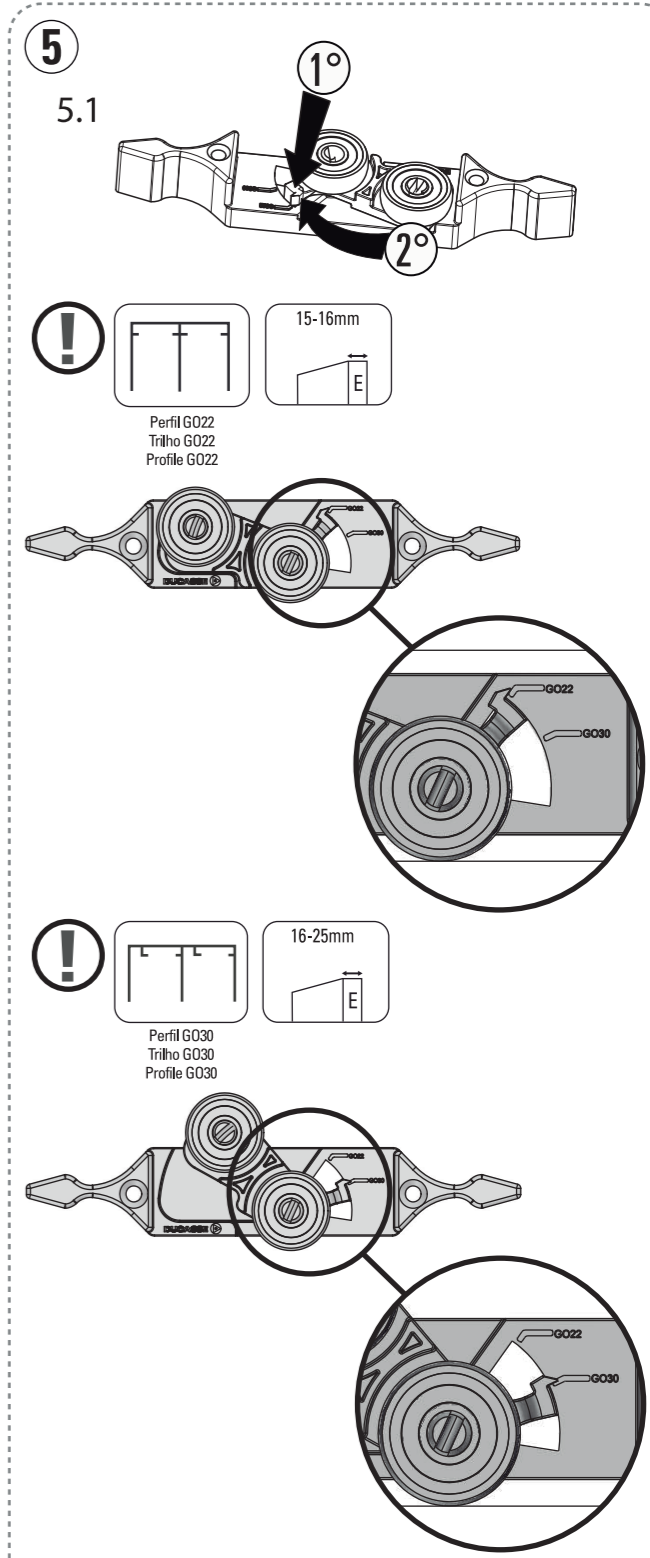
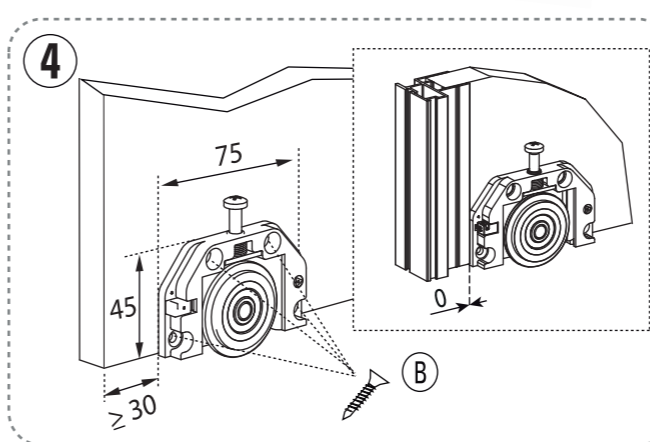
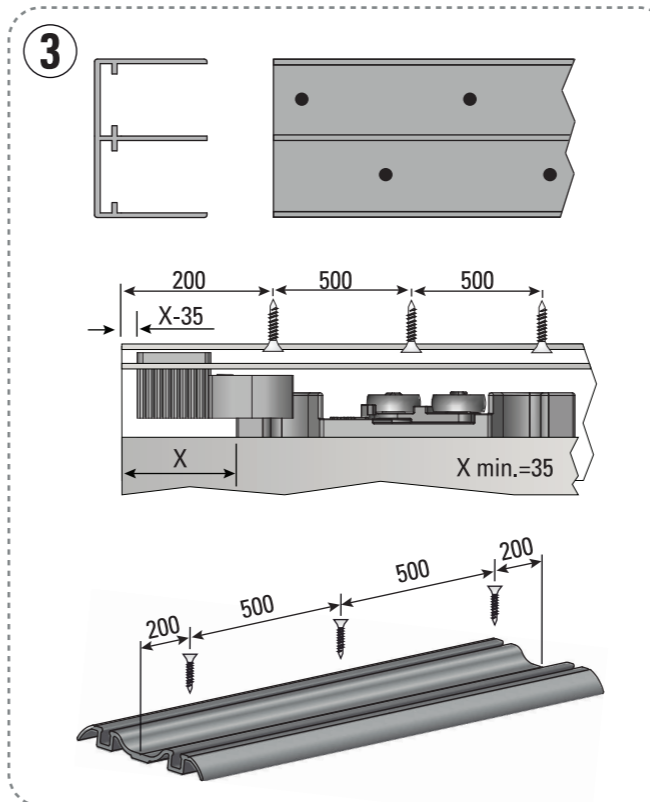
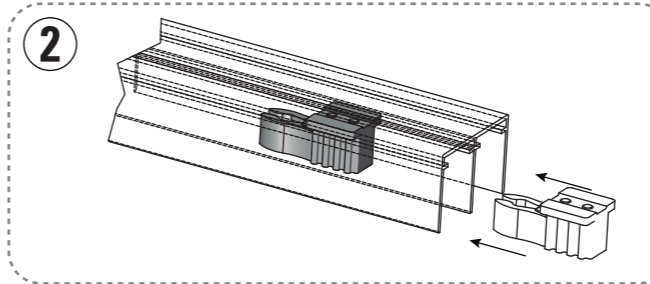
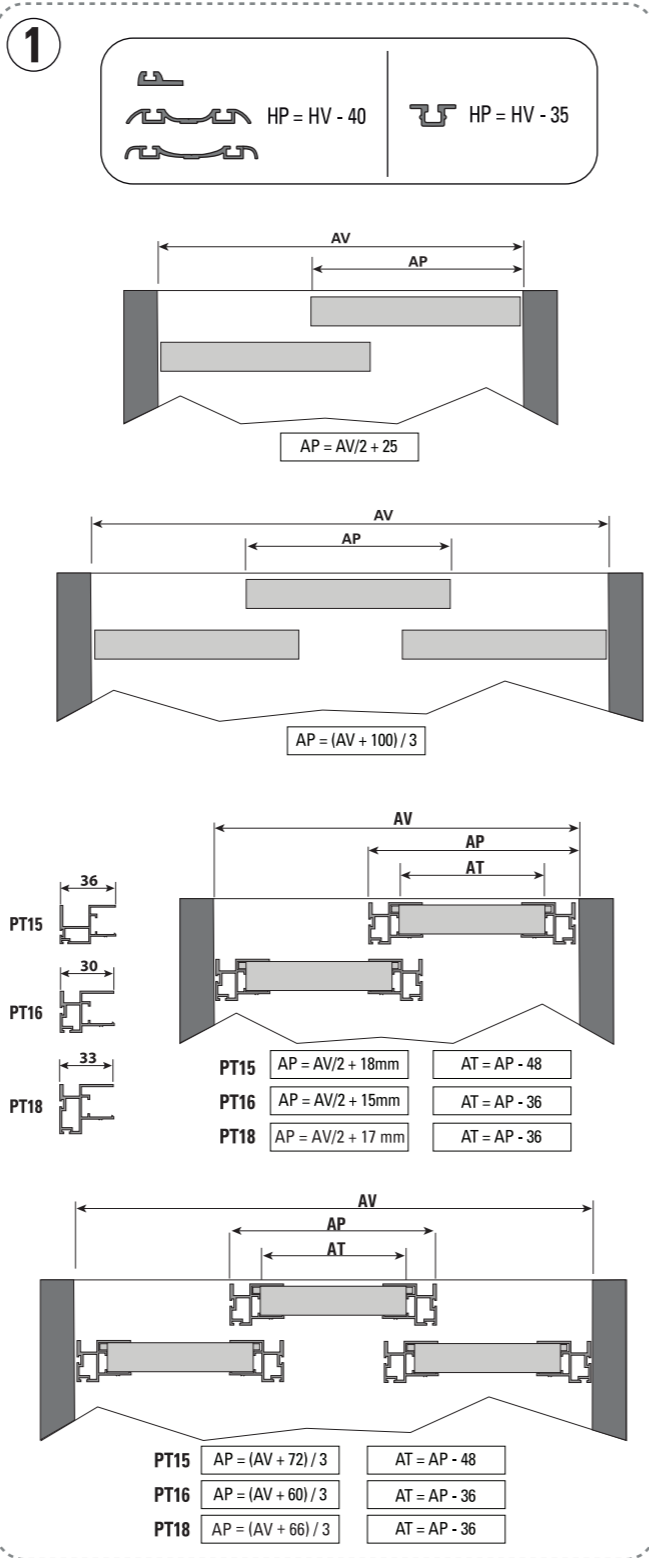

5.2

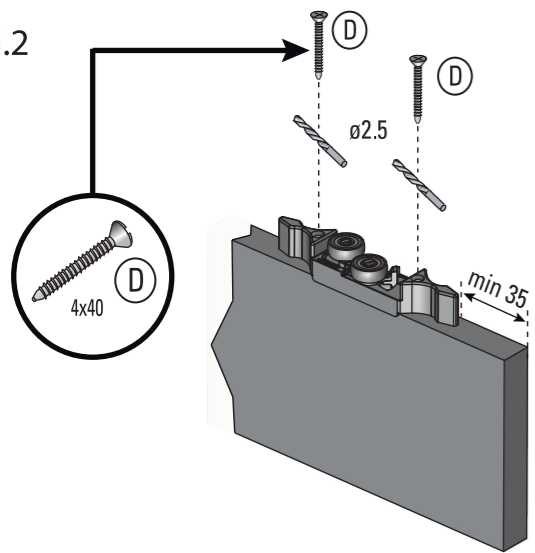

6

CD50-S

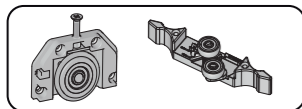

Set CD50-S + EasySoft GOR

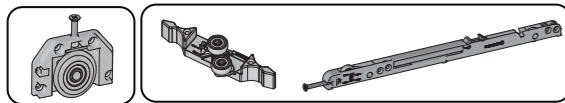

Pt-1

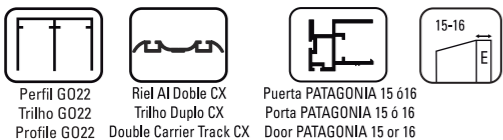

Pt-2

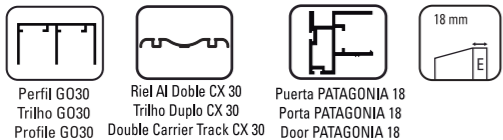

M-1

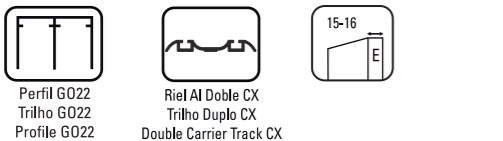

M-2

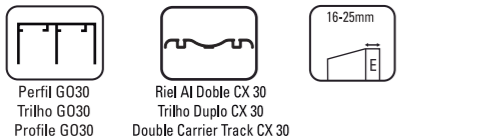

Pt-1

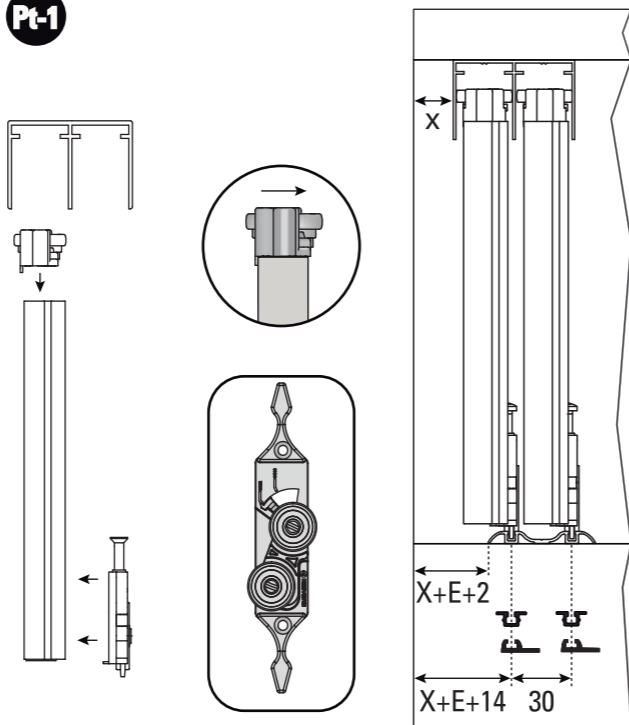

Pt-2

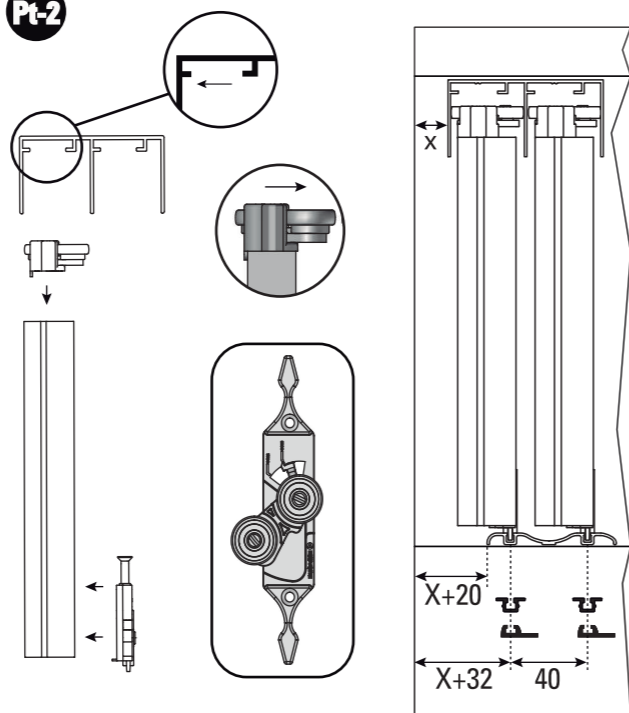

M-1

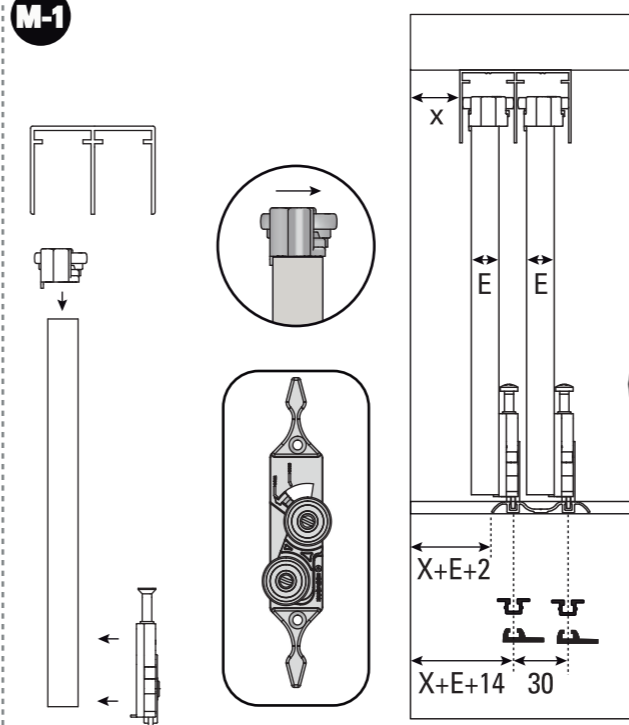

M-2

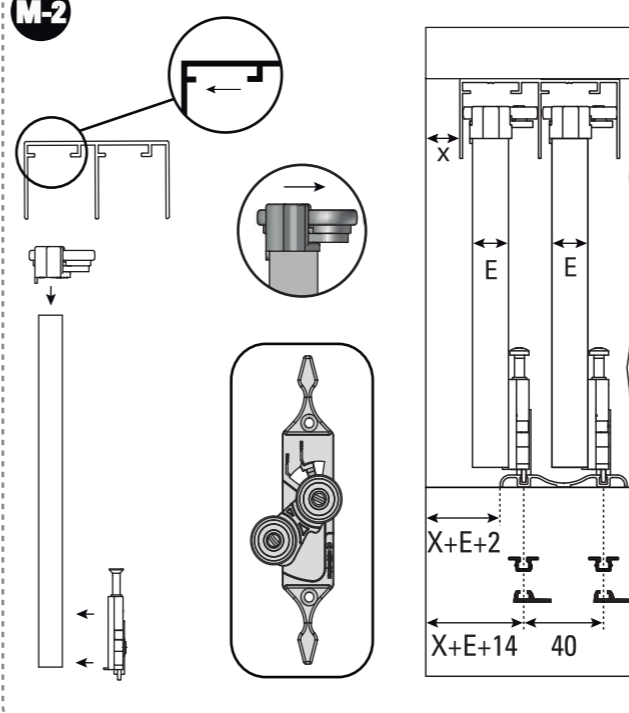

7

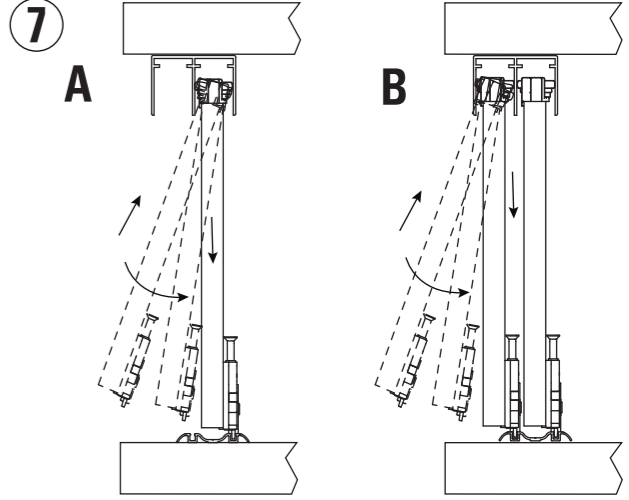

8

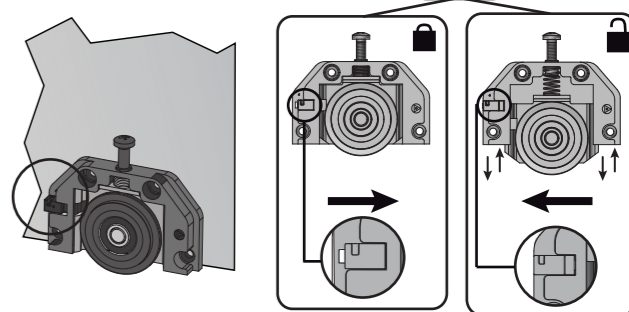

9

