

TAURO PLMD 50

Kit 2 hojas

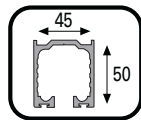
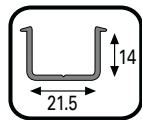

Riel guía PL
Trilho guia PL
PL Guide carrier track

Riel U150 recto
Trilho U150 recto
U150 recto Carrier Track

* NOTA: medidas en mm.

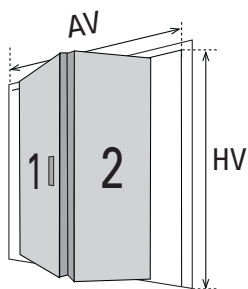

A

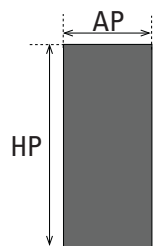

$$HP = HV - 66$$

$$AP = \frac{AV - 10}{2}$$

$$AP \leq 750$$

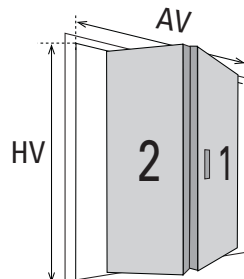

B

A

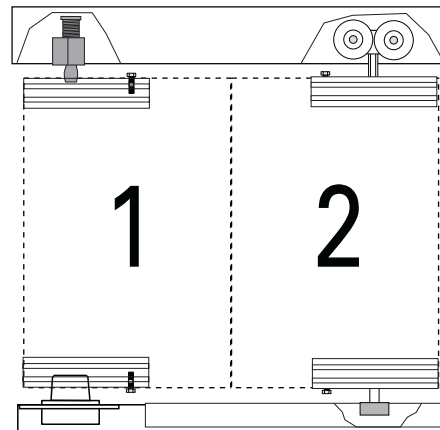

X

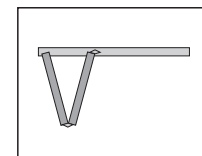
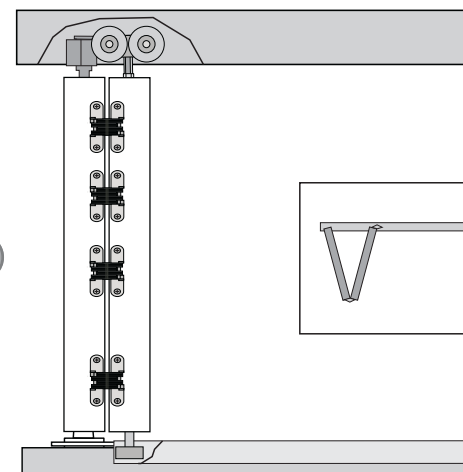

V

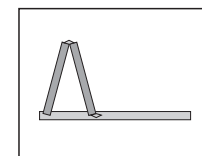
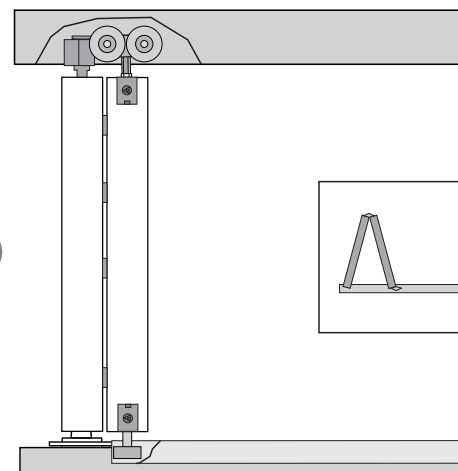

x1	x1	x2	x8		
x1	x1	x2	x1		
x1	x4	x1	x1		
x1	4.5x70 (x12)	4.5x40 (x32)	x1		
	3.5x30 (x2)		x1		

Herramientas necesarias

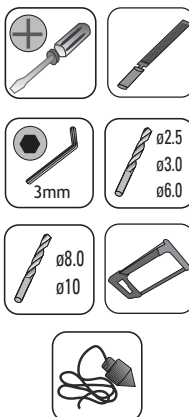

Todas las medidas expresadas en milímetros

Todas as medidas estão em milímetros.

All measurements in millimeters.

mm	Decimal inches	Aprox Fraction	mm	Decimal inches	Aprox Fraction
1	0.0394	3/64	6	0.2362	15/64
2	0.0787	5/64	7	0.2756	9/32
3	0.1181	1/8	8	0.3150	5/16
4	0.1575	5/32	9	0.3543	23/64
5	0.1969	13/64	10	0.3937	25/64

1a

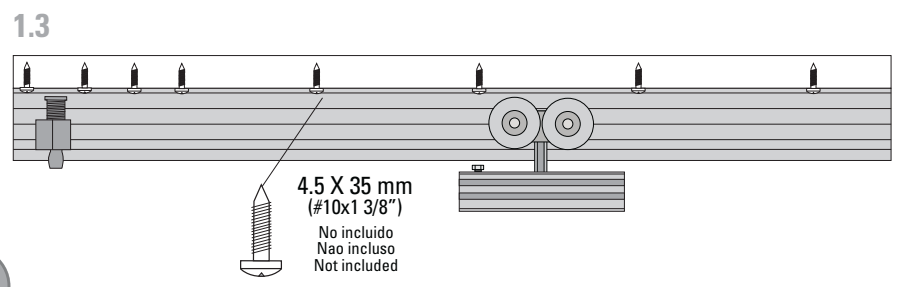
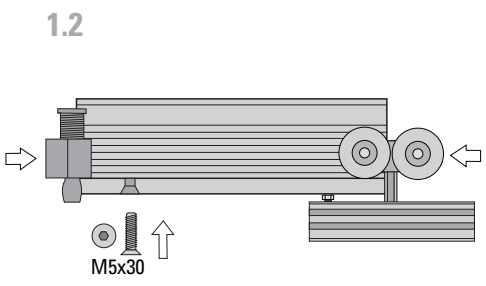
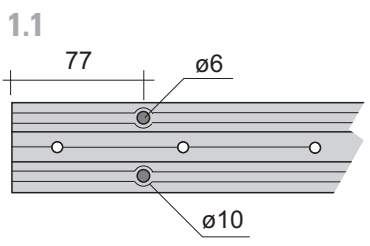
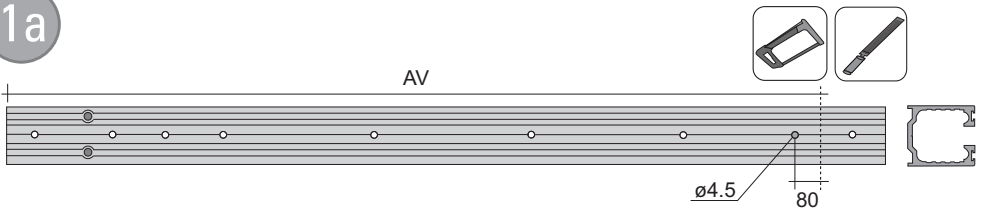

2a

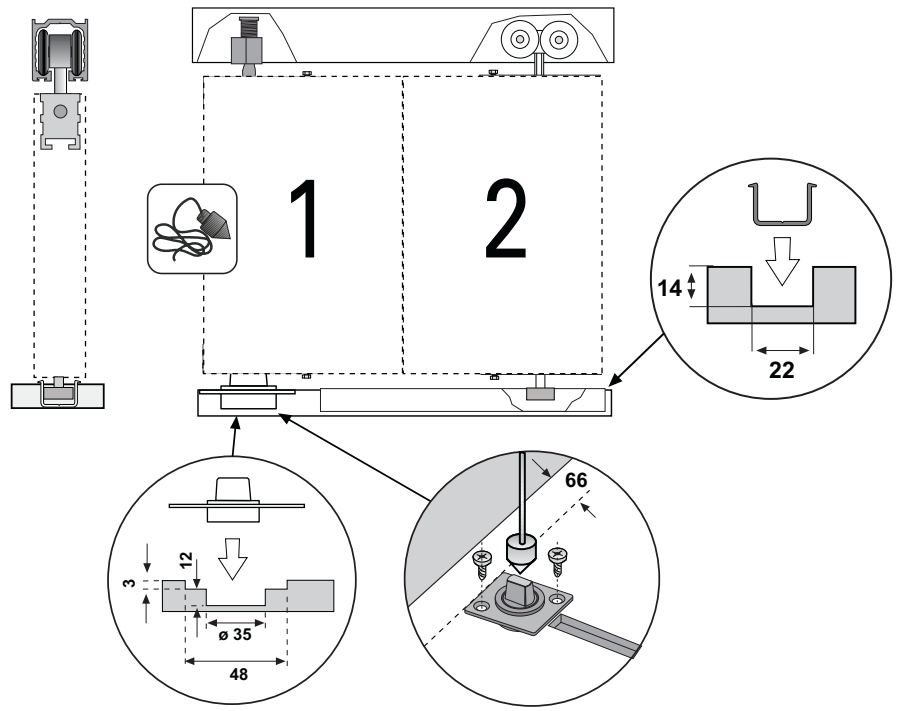

2.1a

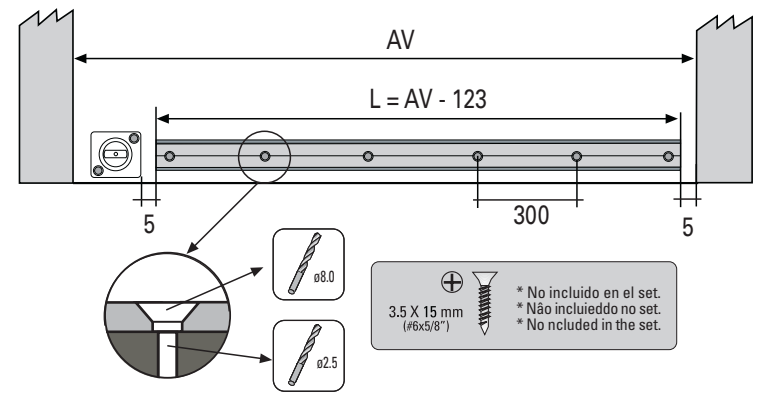

3a

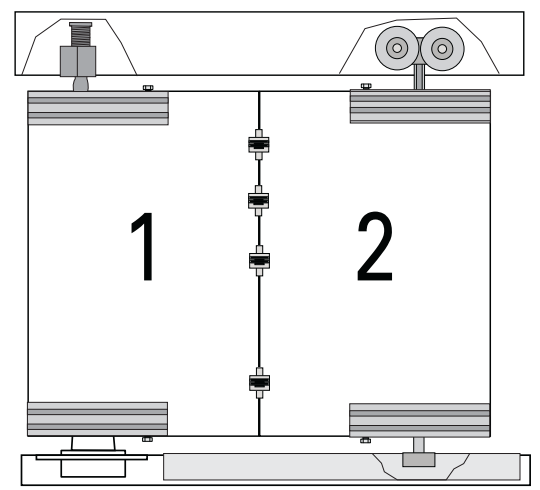

3.1a

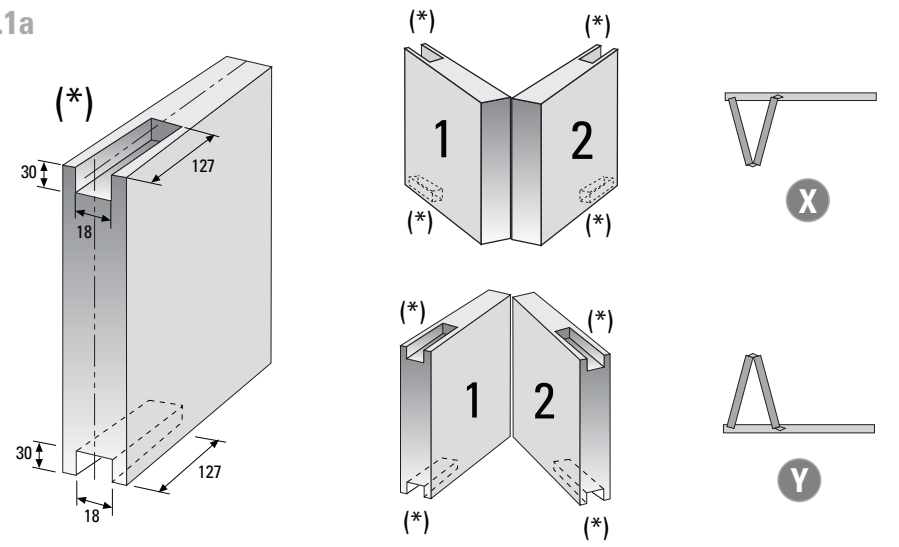

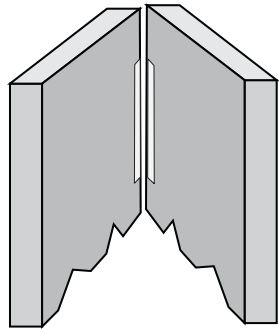
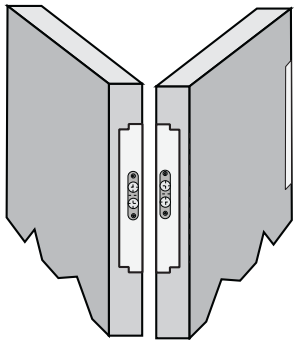
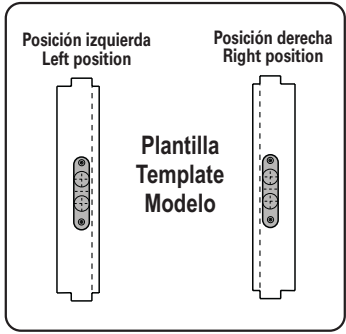
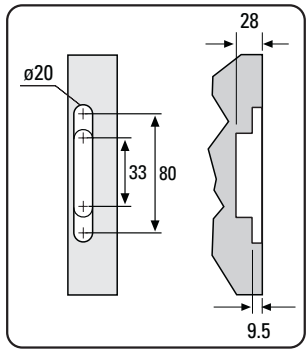

3.2a X

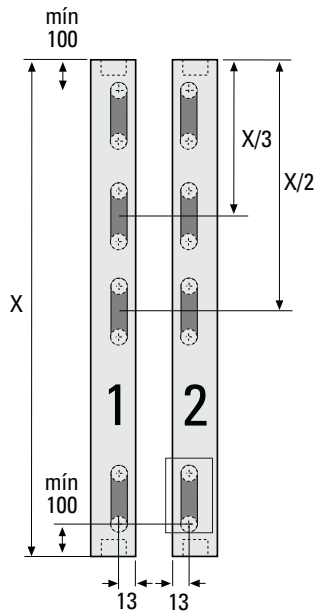
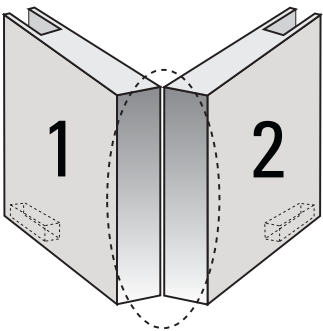

3.3a Y

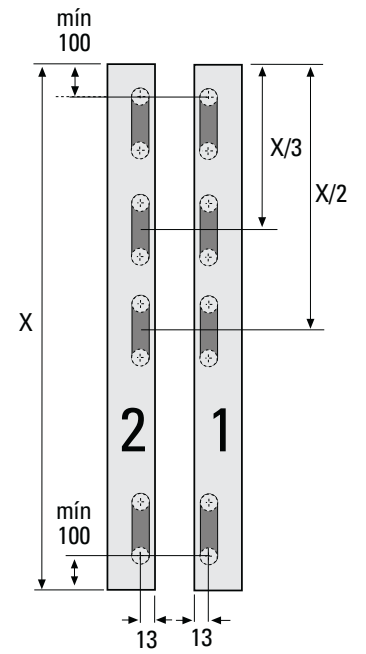
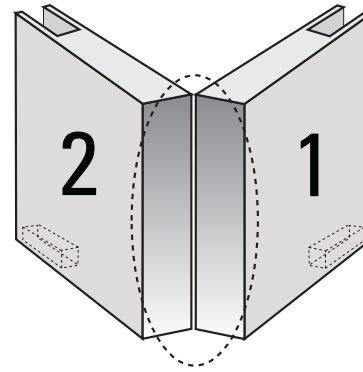

3.4a X Y

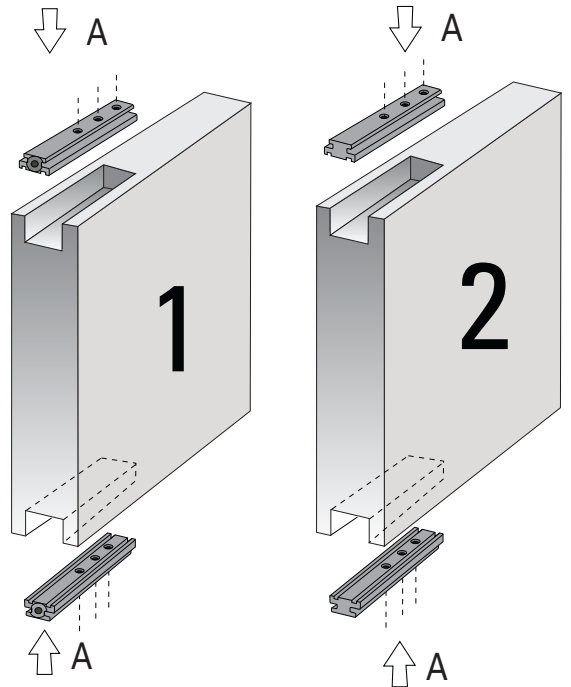
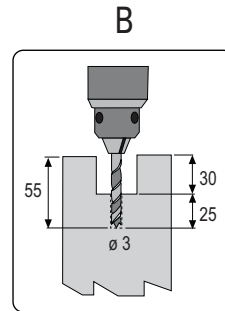

3.5a X Y

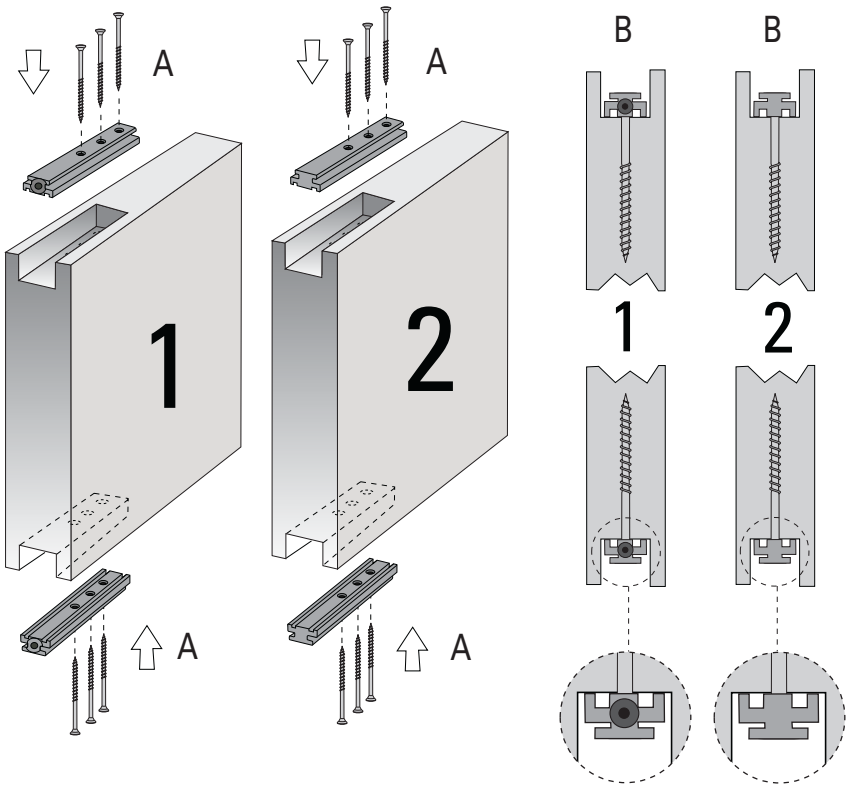

4a x y

4.1a

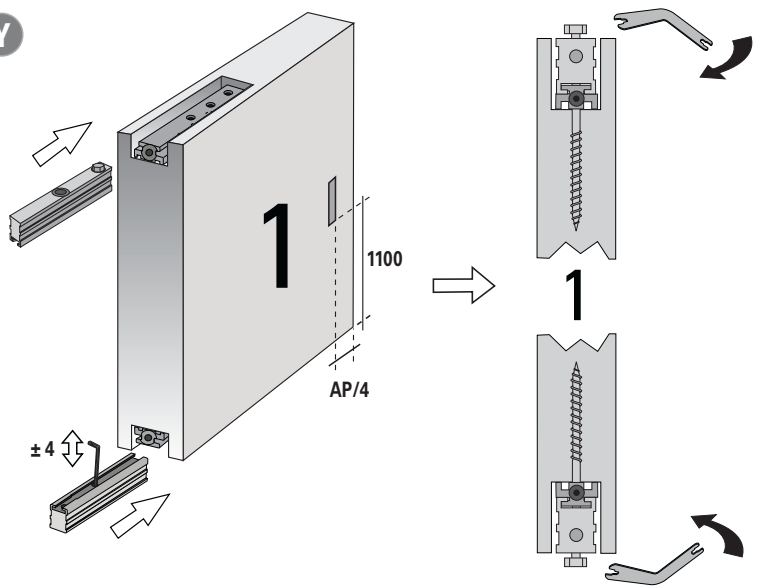

4.2a X

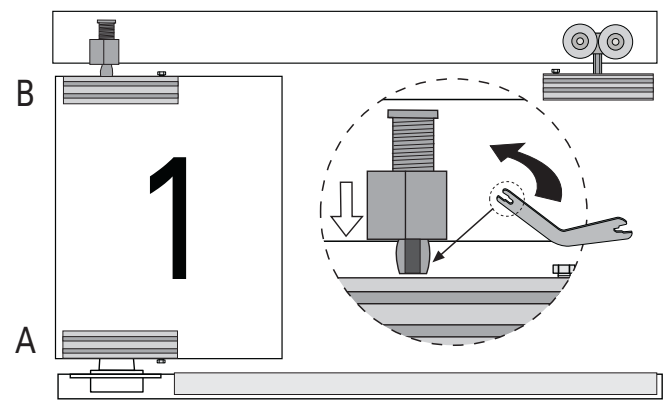

4.3a X

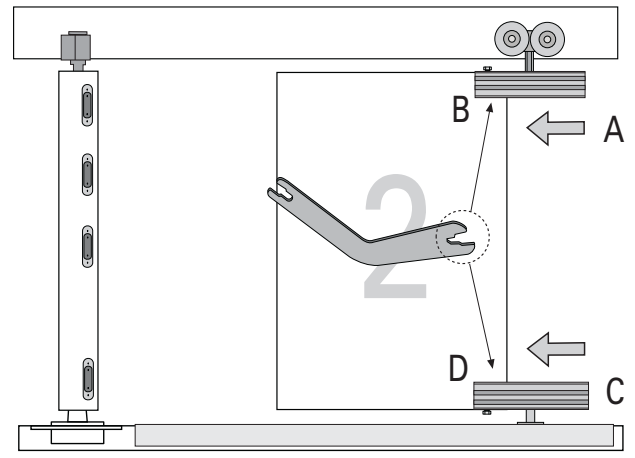

4.4a X

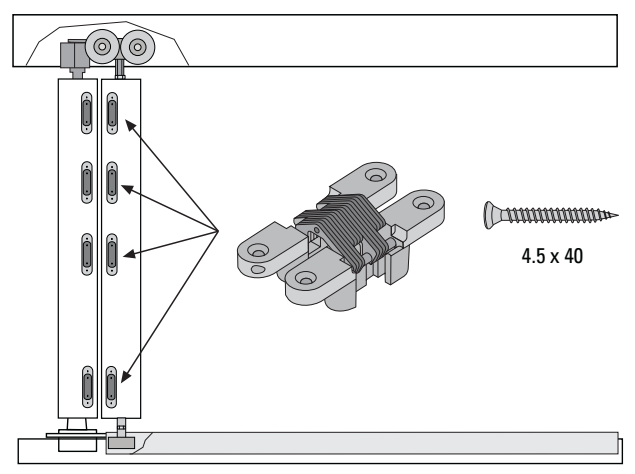

4.5a X

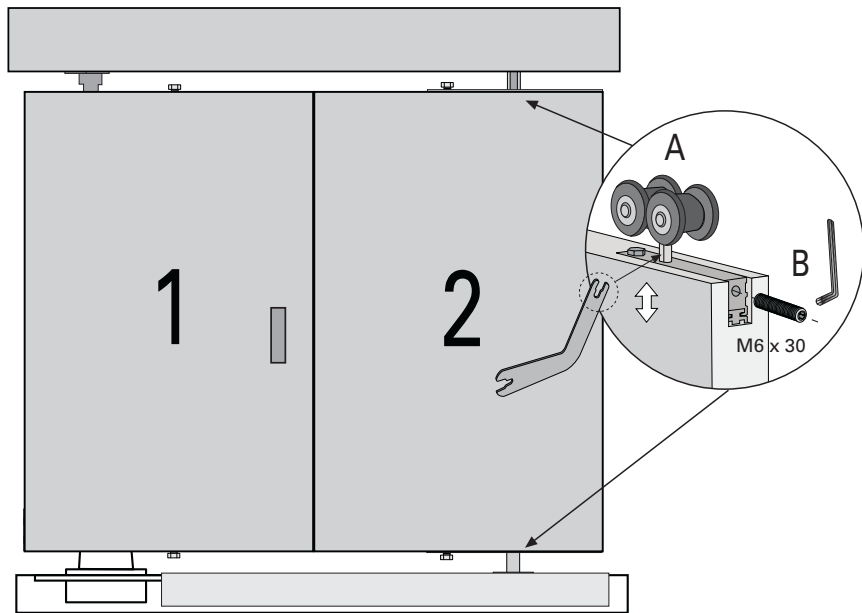

4.6a X

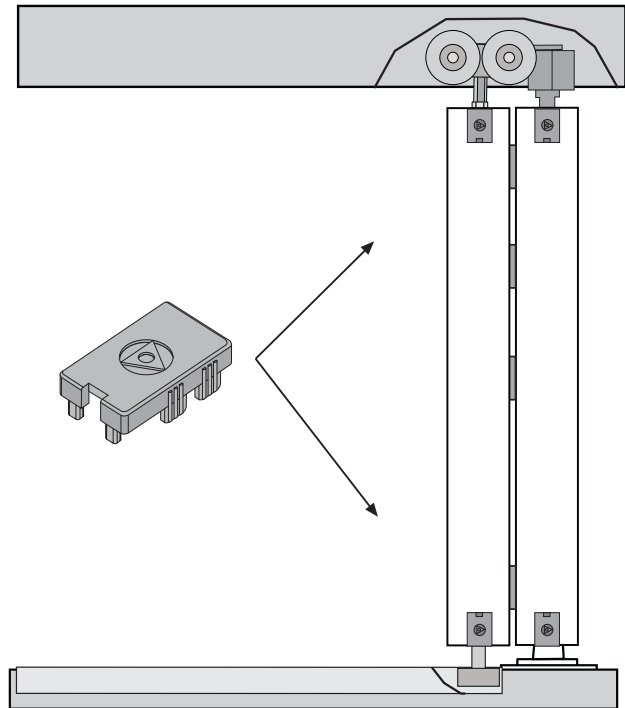

B

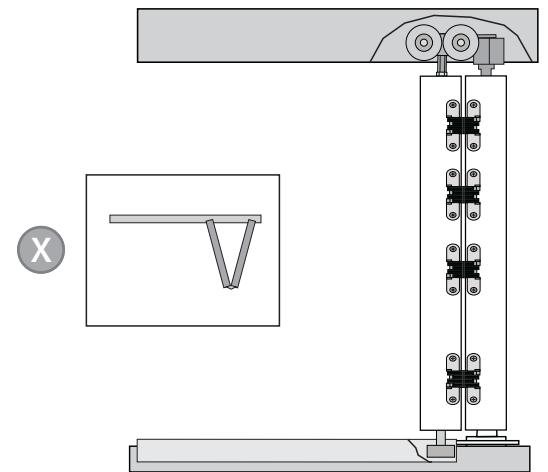
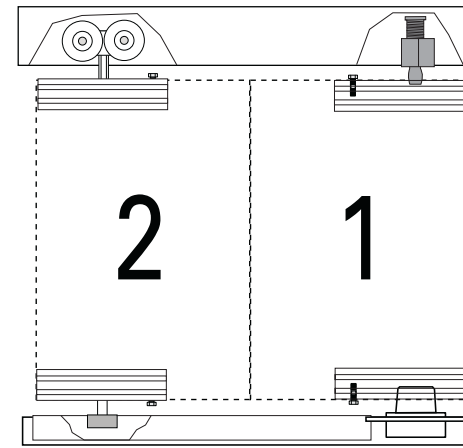

Y

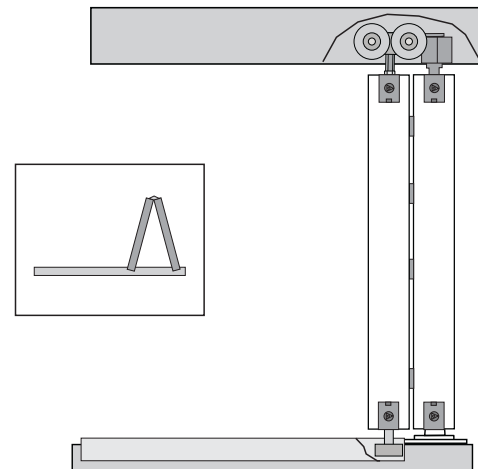

NOTA: Para la configuración Y repetir los pasos desde 4.1a hasta el 4.6a.

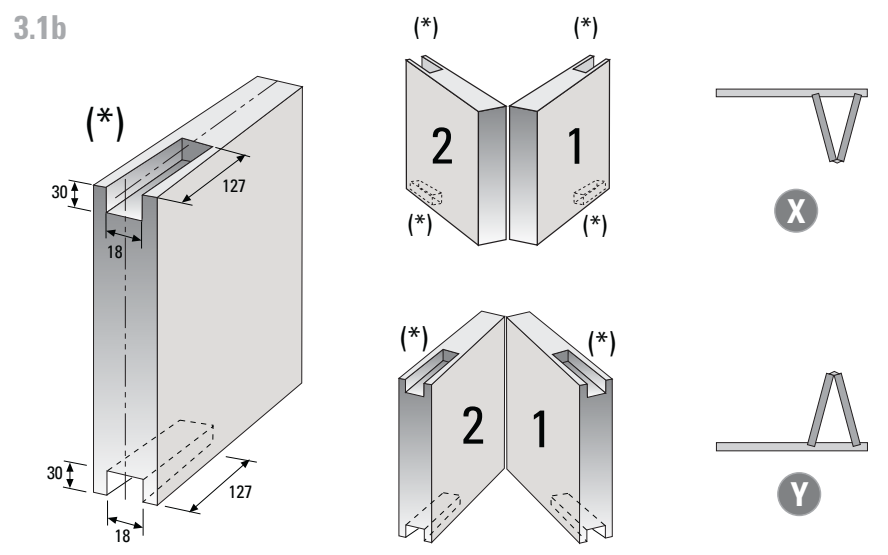
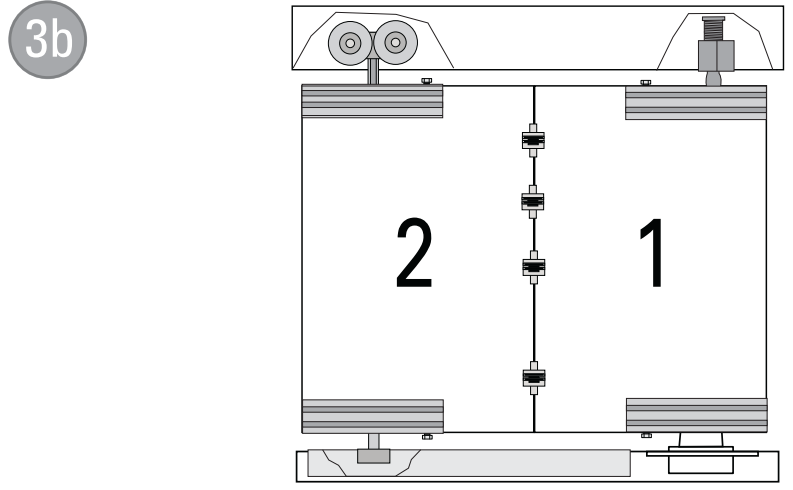
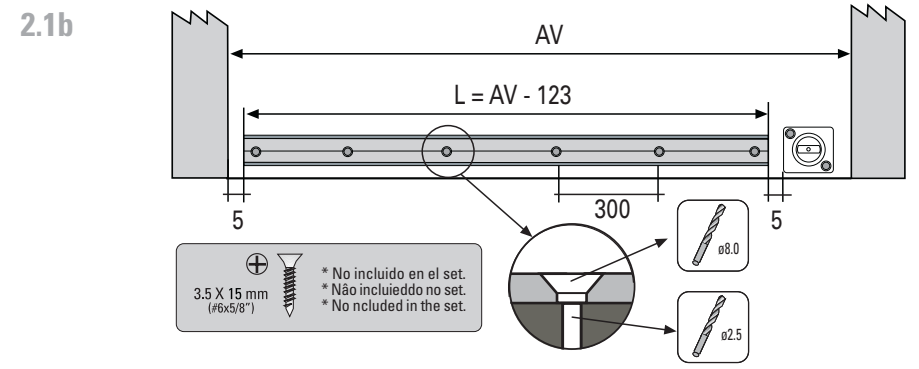
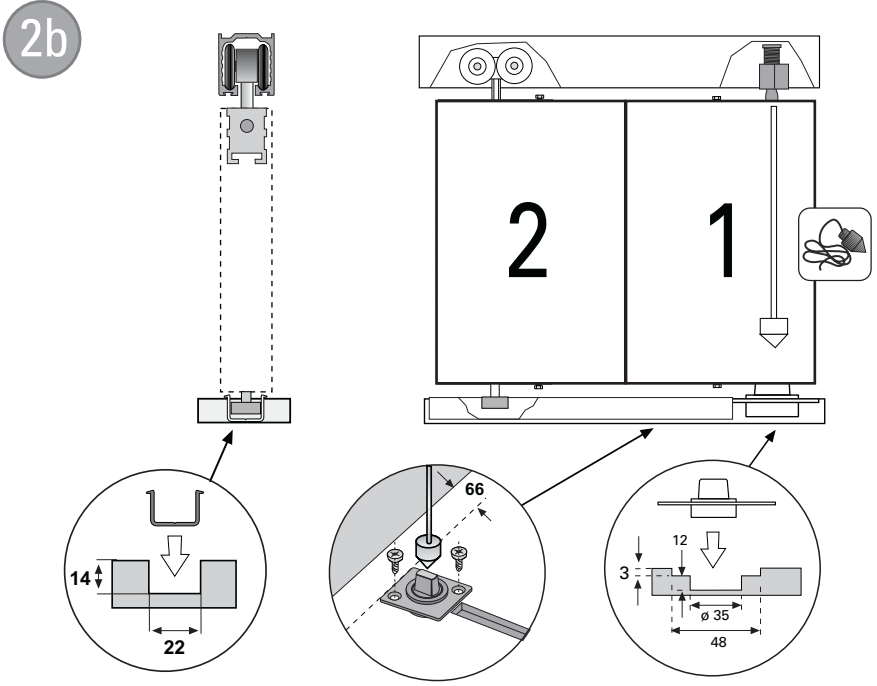
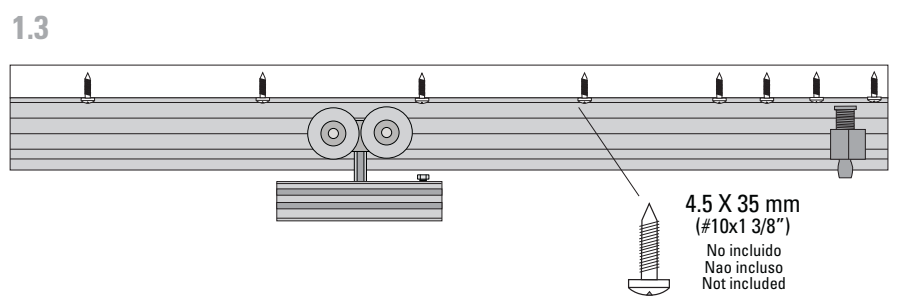
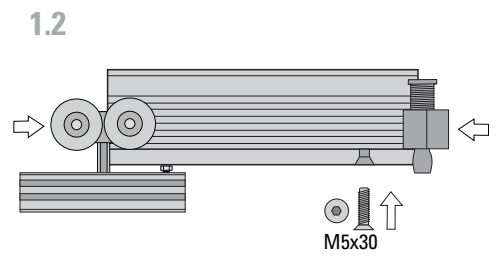
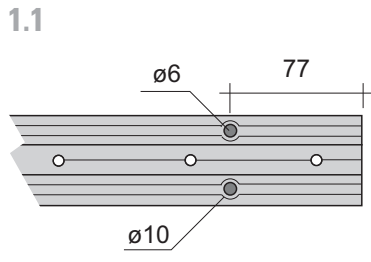
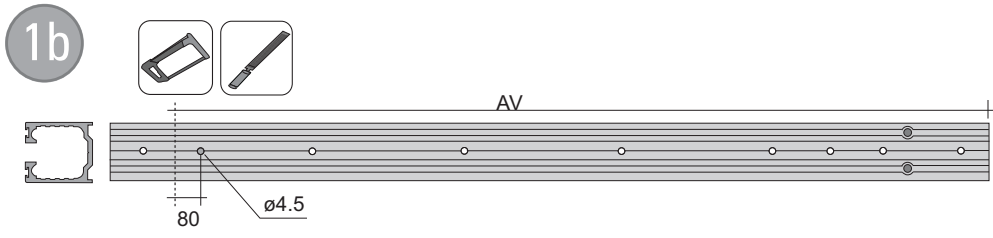

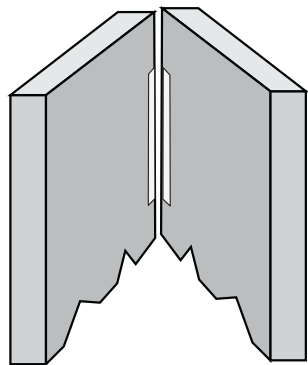
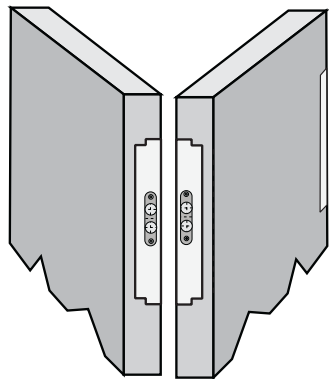
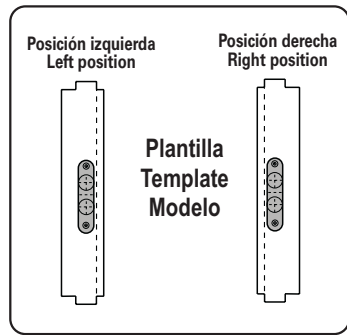
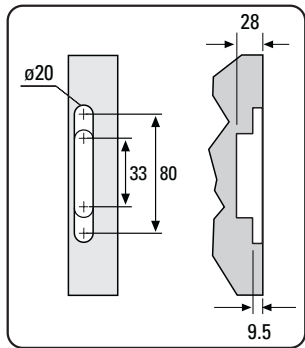

3.2b X

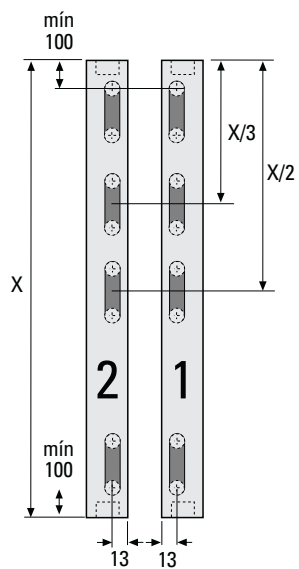
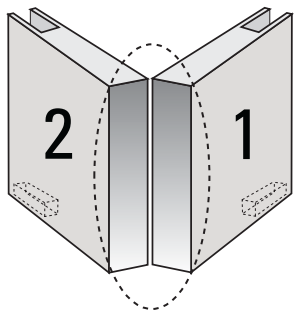

3.3b Y

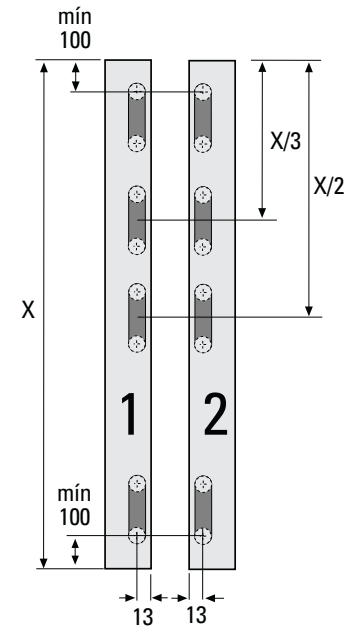
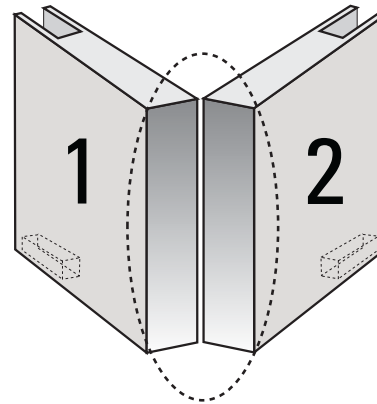

3.4b X Y

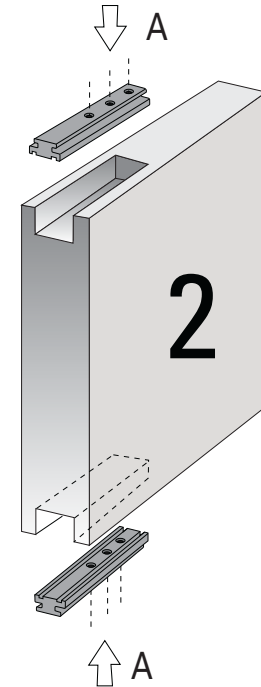
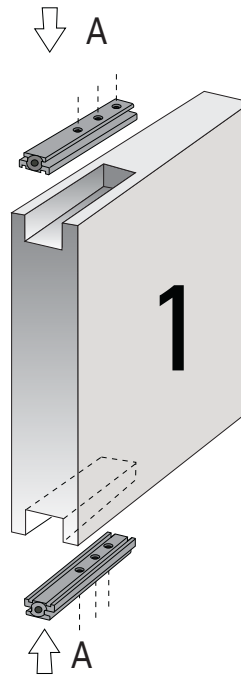
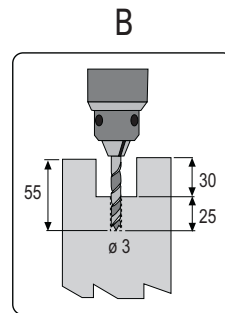

3.5b X Y

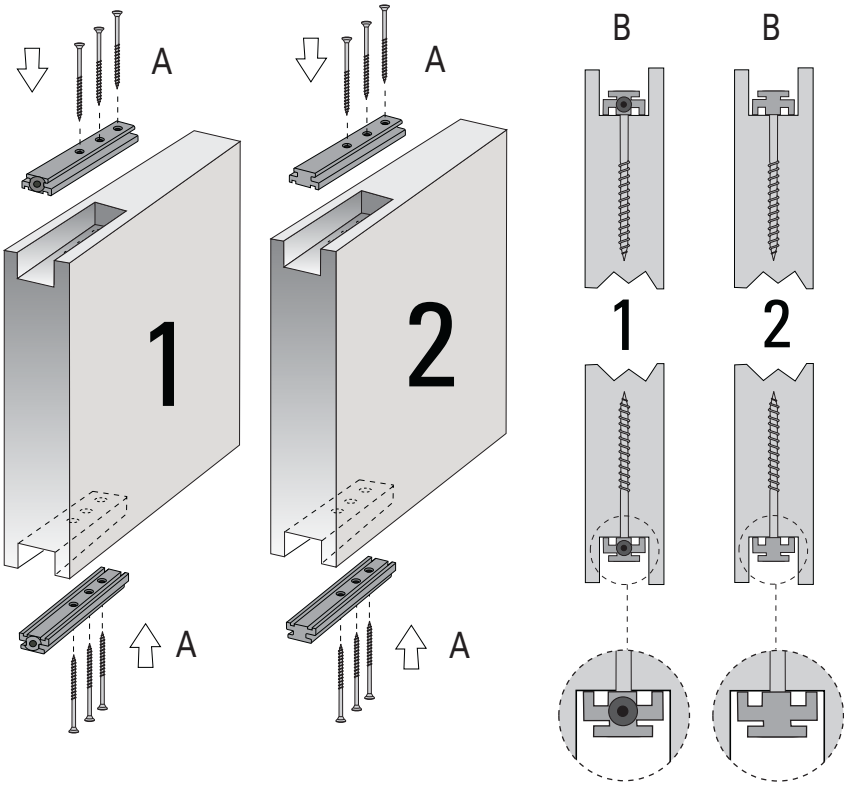

4b X Y

4.1b

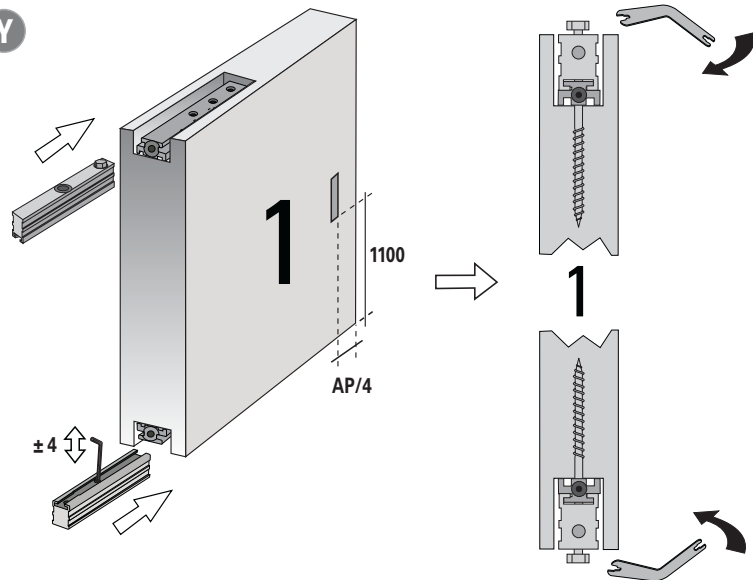

4.2b X

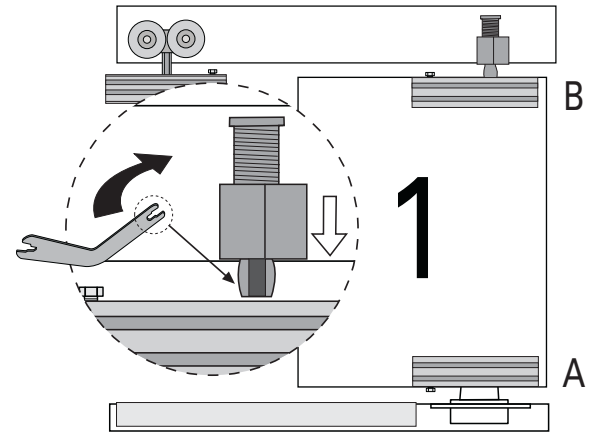

4.3b X

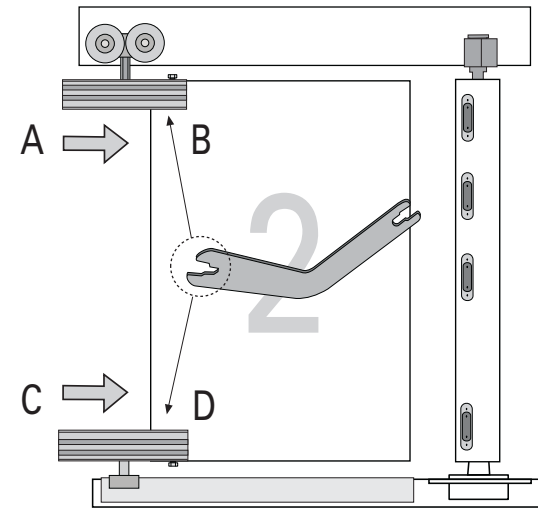

4.4b X

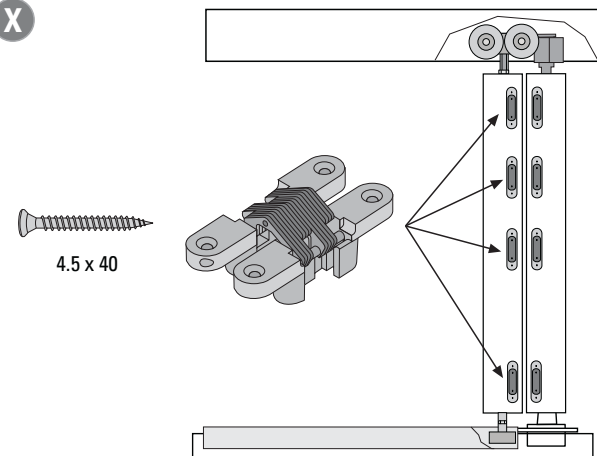

4.5b X

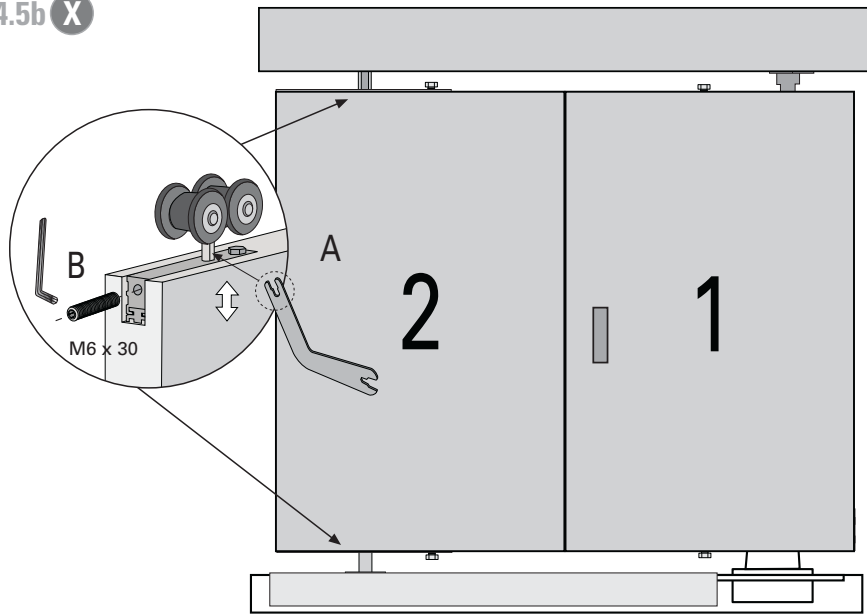

4.6b X

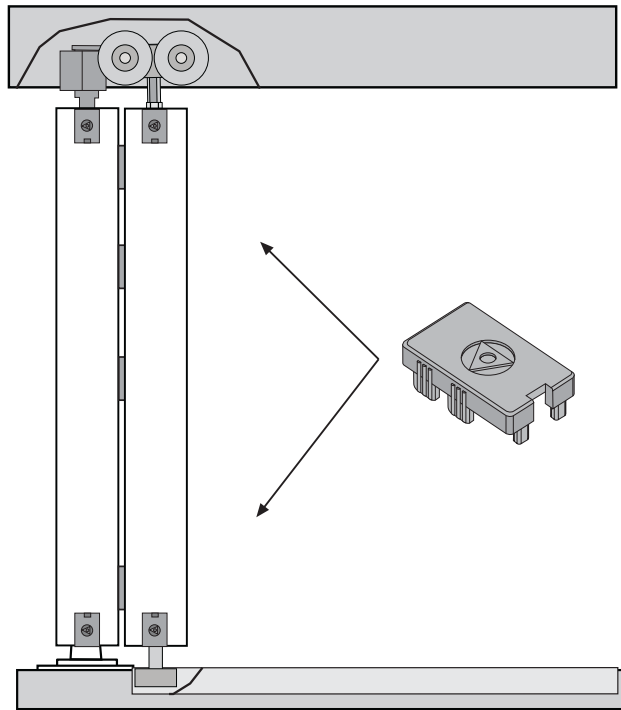

NOTA: Para la configuración Y repetir los pasos desde 4.1b hasta el 4.9b.

5

ACCESORIOS

5.1a X

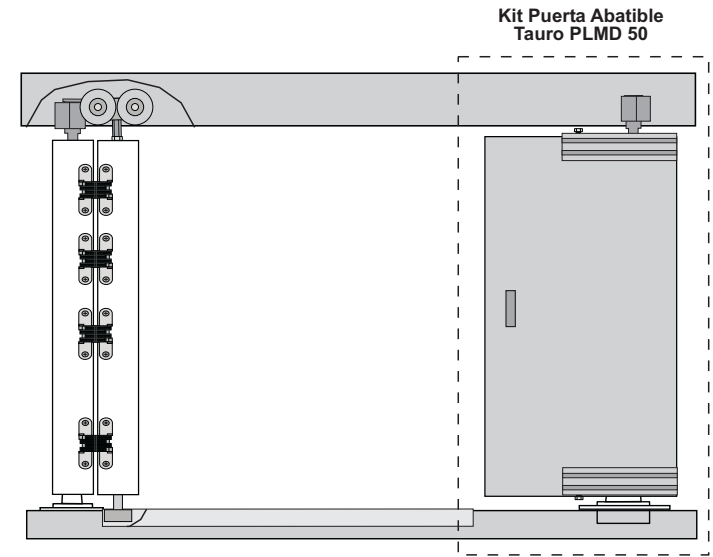

5.2b X

