

# TWIN OP VD

- > Instructivo de montaje pg 02
- > Installation Instructions pg 16
- > Instrutivo de montagem pg 30

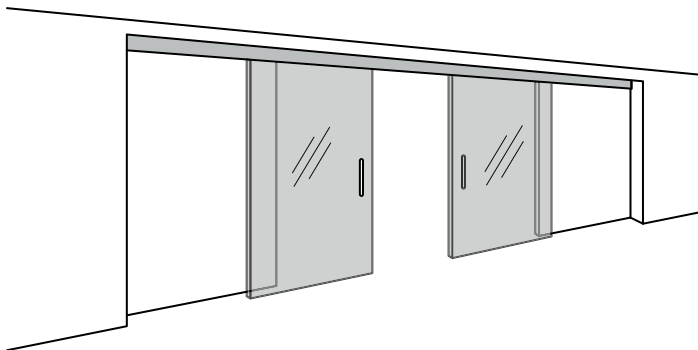

# índice

TWIN OP VD es un sistema corredizo sincronizado para puertas de vidrio, de hasta 80 Kg. cada hoja.

El sistema permite que mediante un sólo movimiento se abran ambas puertas sincronizadamente en sentido opuesto.

- 03 Datos generales y dimensionamiento de puertas.
- 04 Detalle de partes y piezas.
- 05 Paso 1: Instalación de riel, carros y frenos.
- 07 Paso 2: Fijación de la guía al suelo.
- 08 Paso 3: Armado de las puertas.
- 09 Paso 4: Montaje de las puertas.
- 10 Paso 5: Fijación de placas y regulación de altura.
- 11 Paso 6: Fijación de frenos.
- 12 Paso 7: Fijación de la piola.
- 14 Paso 8: Instalación de cenefas.
- 15 Accesorios.

mm	Pulgadas	Fracción
1	0.0394	3/64
2	0.0787	5/64
3	0.1181	1/8
4	0.1575	5/32

mm	Pulgadas	Fracción
5	0.1969	13/64
6	0.2362	15/64
7	0.2756	9/32
8	0.3150	5/16

mm	Pulgadas	Fracción
9	0.3543	23/64
10	0.3937	25/64
11	0.4375	7/16
12	0.4688	15/32

**\*TODAS LAS MEDIDAS ESTÁN INDICADAS EN MILÍMETROS**

## Datos generales y dimensionamiento de puertas



CANTIDAD DE PUERTAS



CAPACIDAD DE CARGA POR HOJA



PARA PUERTAS DE VIDRIO



ESPESOR PUERTA DE VIDRIO



ZONA DE PASO



ANCHO PUERTA

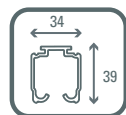

RIEL U21 AL

### Para dimensionar las puertas

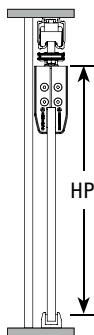
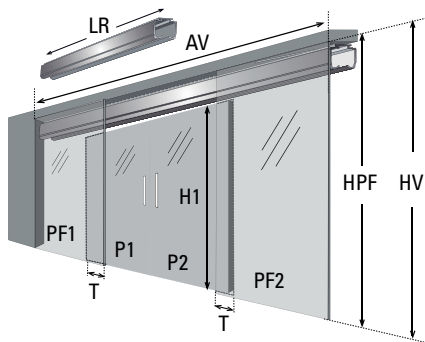

$$LR = 4AP - 2T$$

$$AP = (ZP/2) + T$$

$$H1 = HV - 125$$

$$APF \geq AP$$

$$HPF = HV$$

$$HP = H1 + 51$$

$$T = 50 \text{ min.}$$

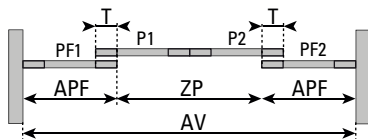







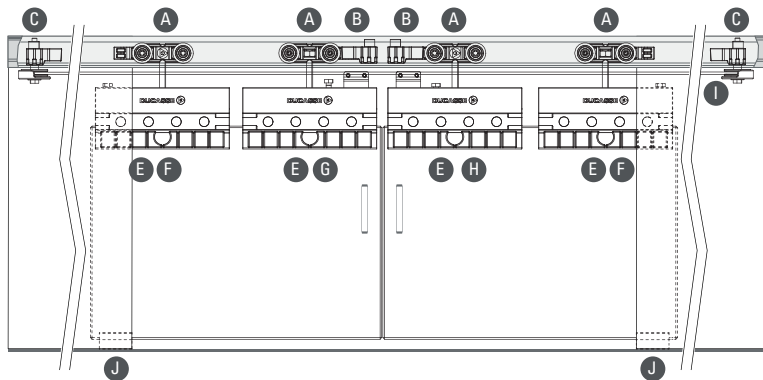





**! Utilizar con cristal templado**





AP = Ancho Puerta | AV = Ancho Vano | H1 = Altura Vidrio | HP = Altura Puerta | HV = Altura Vano  
HPF = Altura Paño Fijo | APF = Ancho Paño Fijo | ZP = Zona de Paso | T = Traslape | LR = Largo Riel

## Detalle de partes y piezas



### TWIN OP VD

<b>A</b>	Carro DN-80		4
<b>B</b>	Frenos DN-80		2
<b>C</b>	Frenos Polea Twin		2
<b>D</b>	Perno carro		4
<b>E</b>	Mordaza Pres/Perf		4
<b>F</b>	Placa twin		2
<b>G</b>	Placa base candado derecha		1
<b>H</b>	Placa base candado izquierda		1
<b>I</b>	Piola 13 mt + cierre candado		1
<b>J</b>	Guía VD + regulador 8-10		2
<b>K</b>	Tapa mordaza izquierda		4
<b>L</b>	Tapa mordaza derecha		4
<b>M</b>	Llave Segmenta		1
<b>N</b>	Llave allen 2.5 / 3 / 4mm		1

<b>O</b>	Pernos M5 x 20		16
<b>P</b>	Tarugos N°6		2
<b>Q</b>	Tornillos #3.5 x 35		2
<b>R</b>	Kit de limpieza		4

### HERRAMIENTAS NECESARIAS

Taladro	
Llave torque	
Plomo	
Destornillador cruz	
Huinchita de medir	

## Instalación de riel, carros y frenos

### Paso 1

- Cortar los rieles según la fórmula indicada y luego perforar.

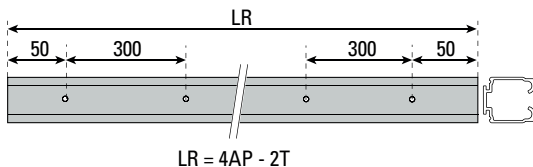

- Armar los conjuntos de carros, introduciendo los pernos a través de las placas y los carros, prestando especial atención a la posición de éstos.

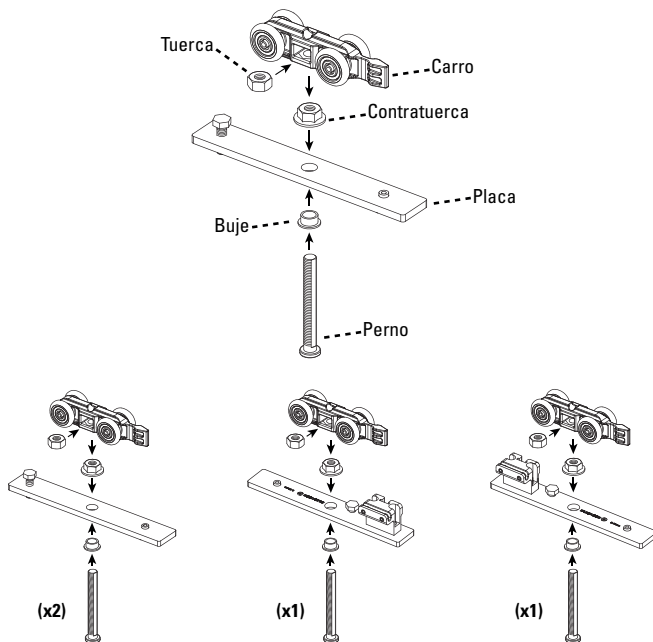

- Introducir en el riel: frenos DN 80, carros y frenos polea, en las posiciones que indican los esquemas.

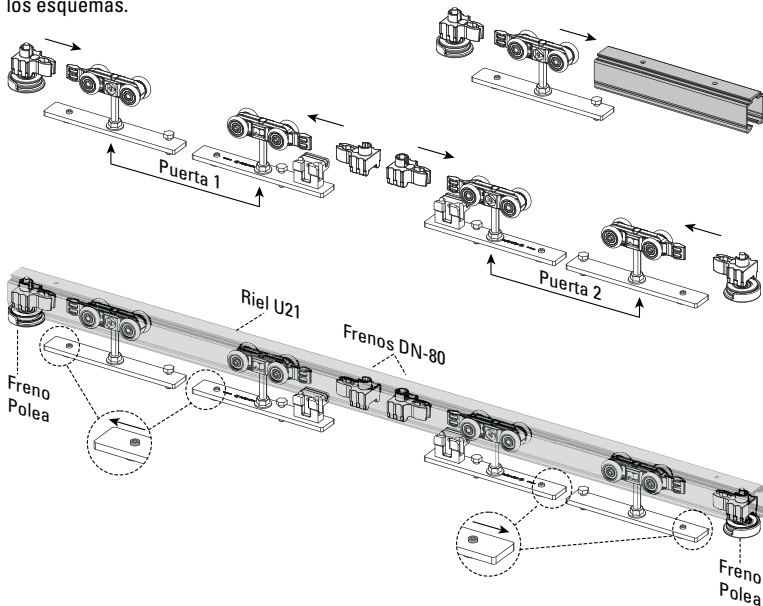

- Fijar los rieles al cielo, tomando en cuenta la distancia indicada en el esquema. (Fijaciones no incluidas).

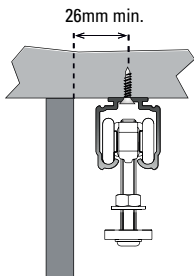

- Después de fijar, limpiar las pistas de los rieles para evitar posibles residuos.

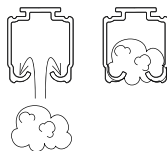

- Aplomar riel para determinar la posición de la Guía VD

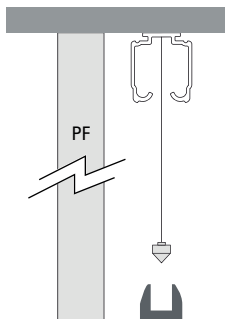

- Posicionar el regulador en la Guía VD, según el espesor de vidrio que se utilice.

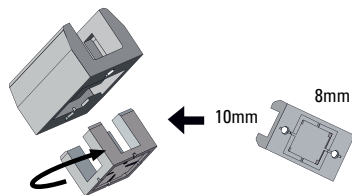

- Fijar la guía al suelo al tope de cada paño fijo, tal como lo indica el esquema, utilizando los tarugos n°6 y luego los tornillos 3.5x35.

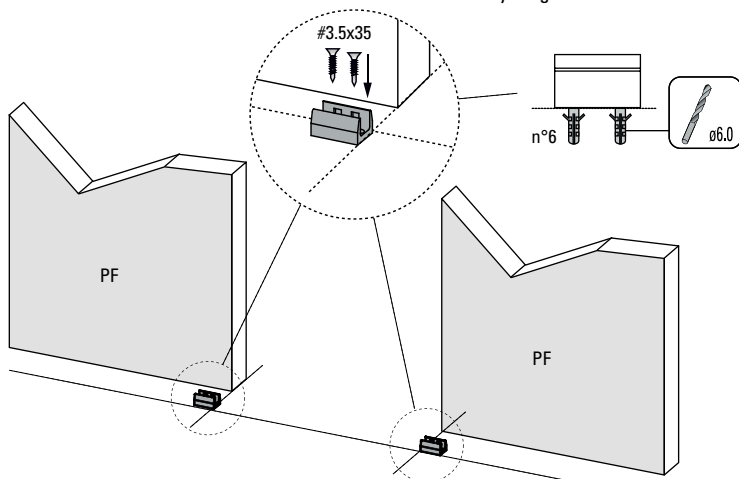

# Paso 3

OPCIÓN (A): Mordazas perforadas / OPCIÓN (B): Mordazas a presión

①

- (A) Mecanizar el vidrio según las indicaciones del esquema.

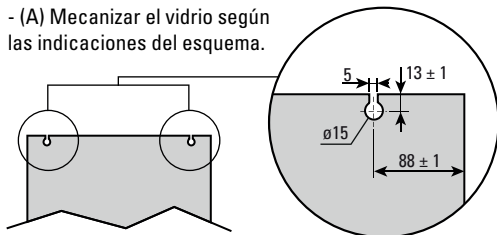

(B) Limpiar el cristal en la zona de instalación de la mordaza con el Kit de limpieza incluido.



②

- (A) y (B) Colocar el distanciador en la posición 8-10mm.

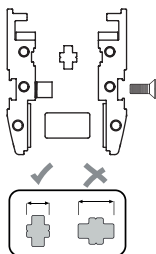

③

- Posicionar la mordaza en el cristal (B) a 6mm del borde.  
- (A) Colocar buje en el cristal.

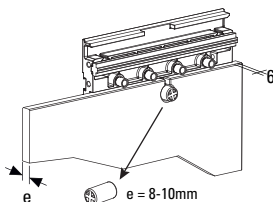

④

- (A) y (B) Colocar la otra parte de la mordaza y apretar los pernos con llave Allen 4mm.

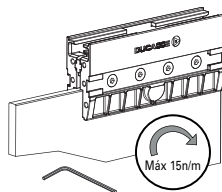

⑤

- (A) y (B) Colocar adhesivos en los extremos.

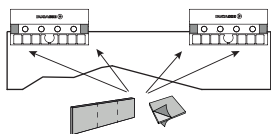

\*\*\* Los topes de las mordazas deben quedar posicionados para un mismo lado.

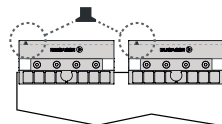

OPCIÓN (A)

- \* Recomendada para cristales sobre 50kg.
- \* Contemplar perforaciones de tiradores.
- \* Recomendada para condiciones de humedad.



- Montar la puerta 1 (P1) sobre la guía VD, cuidando de no dañar la guía telescópica, e introducir las placas en las mordazas.
- De la misma forma montar la puerta 2 (P2) sobre la otra guía VD, como se muestra en el esquema.

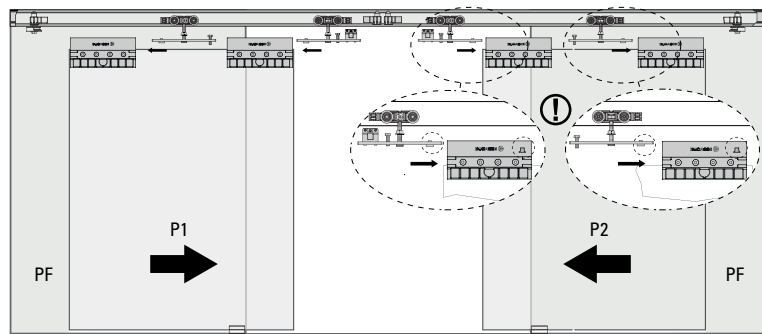
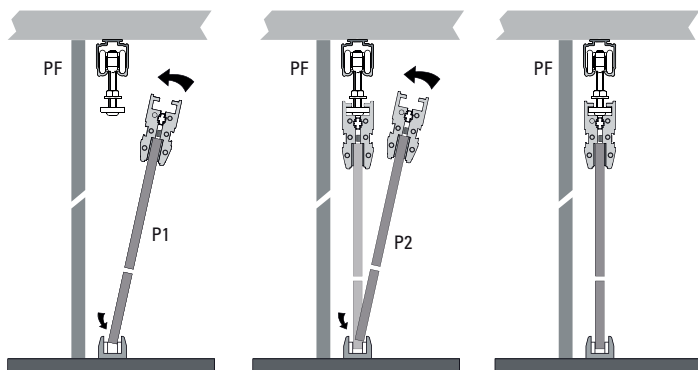

## Paso 5

- Con ayuda de la llave Segmenta, fijar las placas de los carros a las mordazas, ajustando el perno superior, tal como se indica.

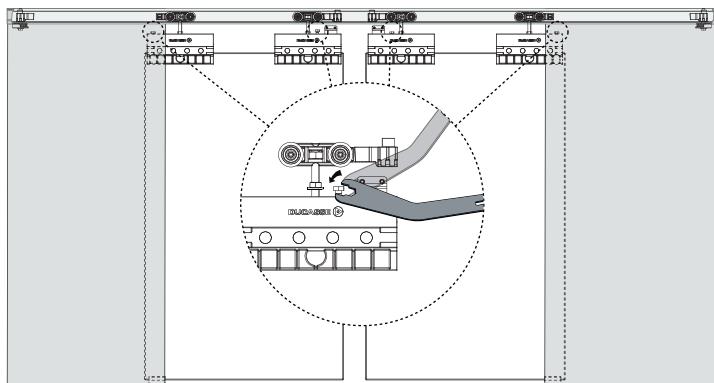

- Regular la altura de los vidrios, ajustando el perno del carro con la llave Segmenta.

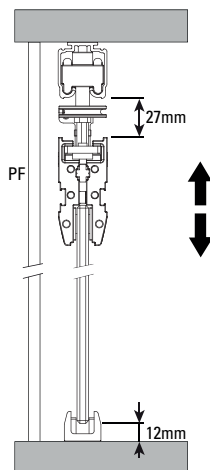
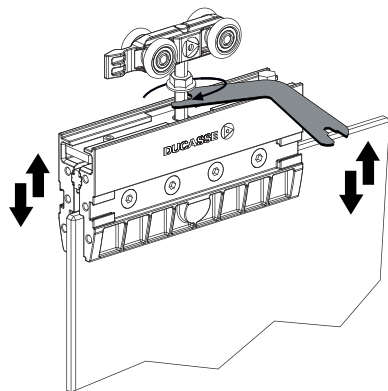

- Llevar las puertas a su posición cerrada y encajar carros con frenos DN 80, en la mitad del riel. Dar la separación de puertas deseada y marcar posición de los frenos.

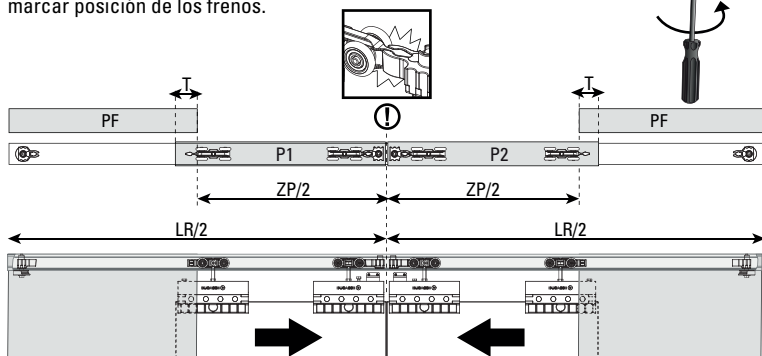

- Abrir las puertas, desclipear los frenos, llevarlos a la marca y fijar con el destornillador, como se muestra en la figura.

- Situar los frenos polea en los extremos del riel y fijarlos con la llave Segmenta.

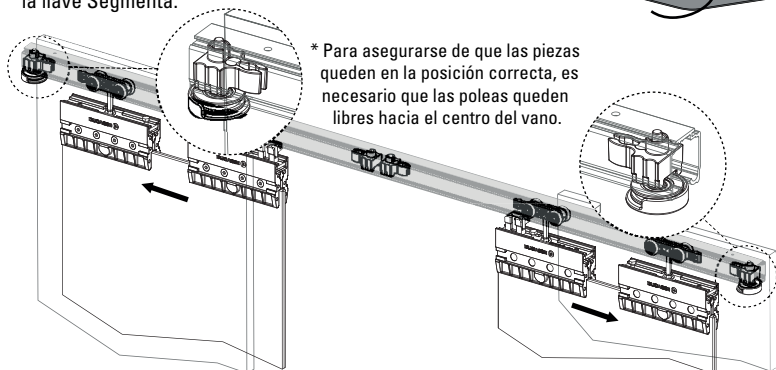
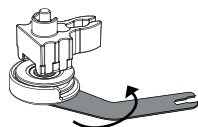

## Paso 7

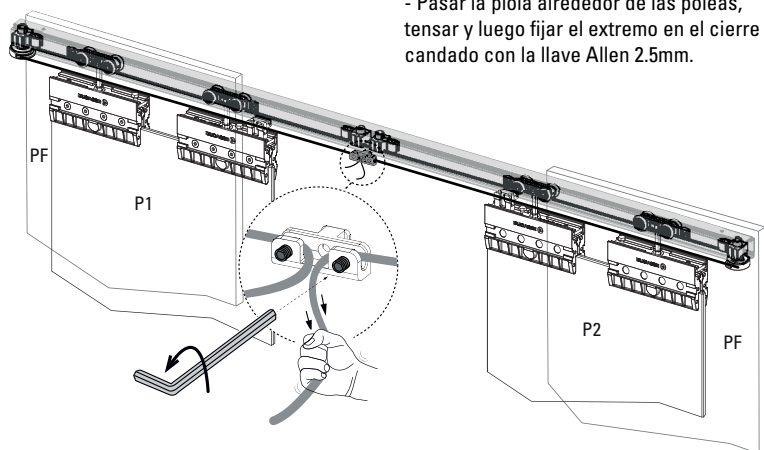

- Montar el cierre candado con la piola en la base candado de la puerta 1 (P1), y luego fijar con la llave Allen 2.5mm.

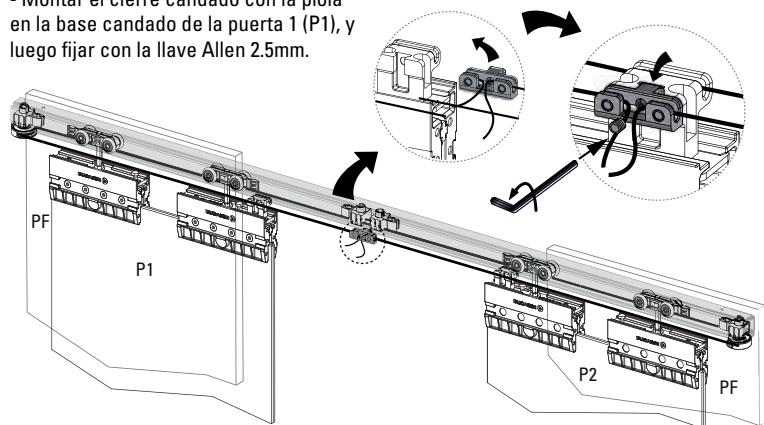

- Luego, con las puertas cerradas, fijar la piola en la base candado de la puerta 2 (P2) con la llave Allen 2.5mm.

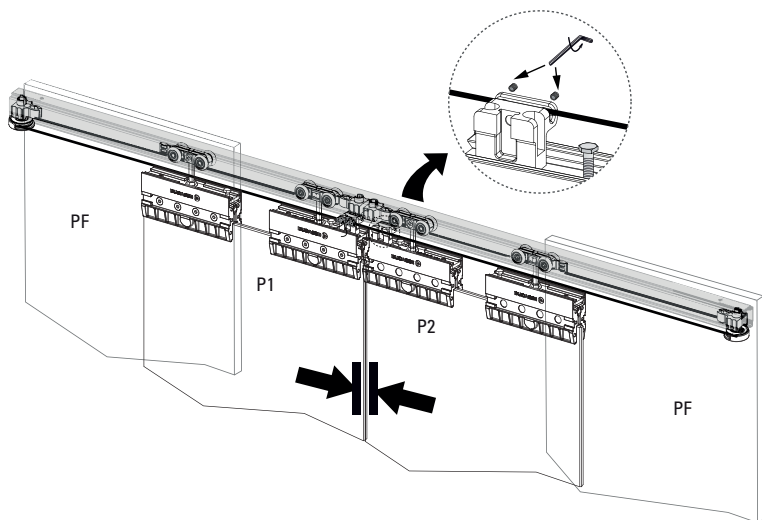

## Paso 8

- Con la llave Segmenta, subir la contratuerca para poder colocar las cenefas en el siguiente paso.

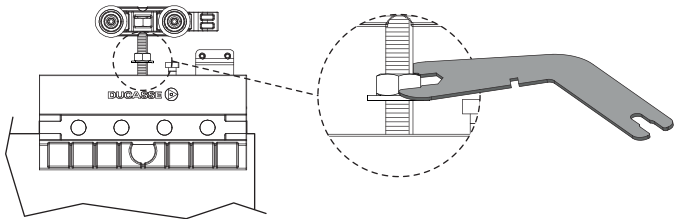

- Clippear la cenefa en las mordazas de la puerta y luego fijar las tapas derechas e izquierdas por ambos costados, con los pernos M5 x 20 y la llave Allen 3mm.

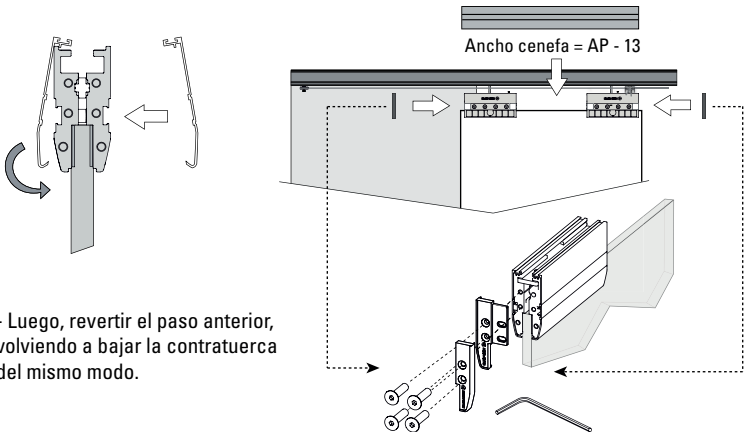

- Luego, revertir el paso anterior, volviendo a bajar la contratuerca del mismo modo.

## Accesorios

**1** CENEFA U-21 66x8

**2** CENEFA U-21 120x8

**3** TAPA U-21 CENEFA 66x8

**4** TAPA U-21 CENEFA 120x8

**5** TAPA MORDAZA ZK

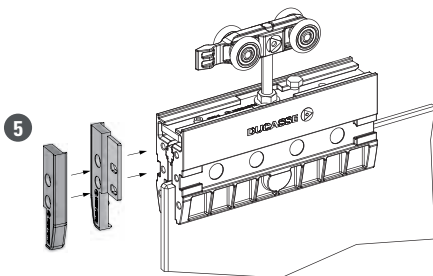
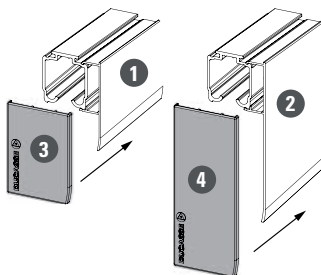

# index

TWIN OP VD is a synchronized sliding system for glass doors of up to 80 Kg. each sheet.

The system allows the synchronized, opposite direction opening of both doors with only a single movement.

- 17 General data and door sizing.
- 18 Detail of parts and pieces.
- 19 Step 1: Track, carrier and stopper installation.
- 21 Step 2: Set-up of the guide to the floor.
- 22 Step 3: Doors Set-up.
- 23 Step 4: Doors mounting.
- 24 Step 5: Plates fixing and height regulation.
- 25 Step 6: Stoppers Set-up.
- 26 Step 7: Cable Set-up.
- 28 Step 8: Fascias Set-up.
- 29 Accessories.

mm	Inches	Fraction
1	0.0394	3/64
2	0.0787	5/64
3	0.1181	1/8
4	0.1575	5/32

mm	Inches	Fraction
5	0.1969	13/64
6	0.2362	15/64
7	0.2756	9/32
8	0.3150	5/16

mm	Inches	Fraction
9	0.3543	23/64
10	0.3937	25/64
11	0.4375	7/16
12	0.4688	15/32

**\*ALL MEASUREMENTS ARE EXPRESSED IN MILLIMETERS**



## General data and door sizing.



NUMBER OF DOORS



LOAD CAPACITY PER SHEET



FOR GLASS DOORS



GLASS DOORS THICKNESS



TRANSIT AREA



DOOR WIDTH

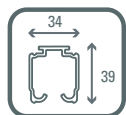

TRACK U21 AL

### Doors sizing

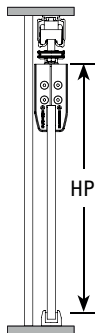
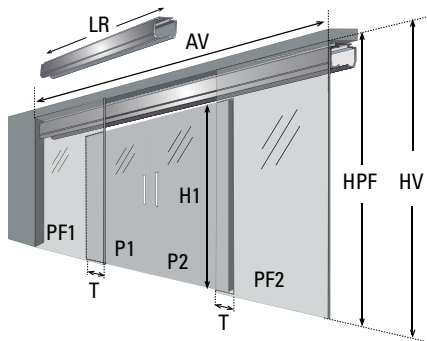

$$LR = 4AP - 2T$$

$$AP = (ZP/2) + T$$

$$H1 = HV - 125$$

$$APF \geq AP$$

$$HPF = HV$$

$$HP = H1 + 51$$

$$T = 50 \text{ min.}$$

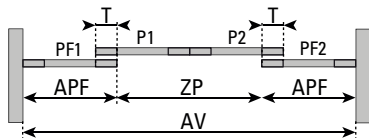







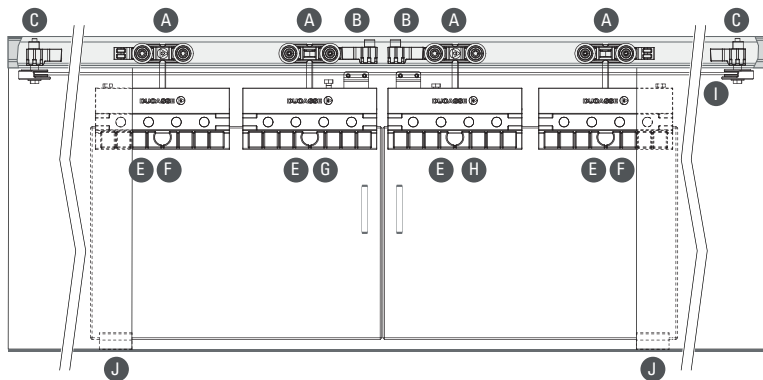







**!** Use with tempered glass





AP = Door Width | AV = Opening Width | H1 = Glass Height | HP = Door Height | HV = Opening Height  
 HPF = Fixed Panel Height | APF = Fixed Panel Width | ZP = Transit Area | T = Overlap | LR = Track Length

## Detail of parts and pieces







### TWIN OP VD

<b>A</b>	DN 80 Carriers		4
<b>B</b>	Stoppers DN 80		2
<b>C</b>	Twin pulley stoppers		2
<b>D</b>	Carrier bolt		4
<b>E</b>	Superior clamp		4
<b>F</b>	Twin Plate		2
<b>G</b>	Lock Plate (right)		1
<b>H</b>	Lock Plate (left)		1
<b>I</b>	13 mts of cable + cable locker		1
<b>J</b>	Floor guide VD + regulator 8-10		2
<b>K</b>	Clamp end left cap		4
<b>L</b>	Clamp end right cap		4
<b>M</b>	Segmenta key		1
<b>N</b>	Allen key 2.5 / 3 / 4mmv		1

<b>O</b>	Bolts M5 x 20		16
<b>P</b>	Dowels n°6		2
<b>Q</b>	Screws #3.5 x 35		2
<b>R</b>	Clean kit		4

### NECESSARY TOOLS

Drill	
Torque wrench	
Plumb line	
Phillips screwdriver	
Measuring tape	

## Track, carrier and stopper installation

step 1

- Cut the tracks according with the shown formula and then, drill.

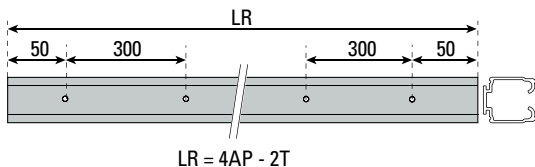

- Set up the carrier sets, inserting the carrier bolts through the plates and carriers, paying special attention to their position.

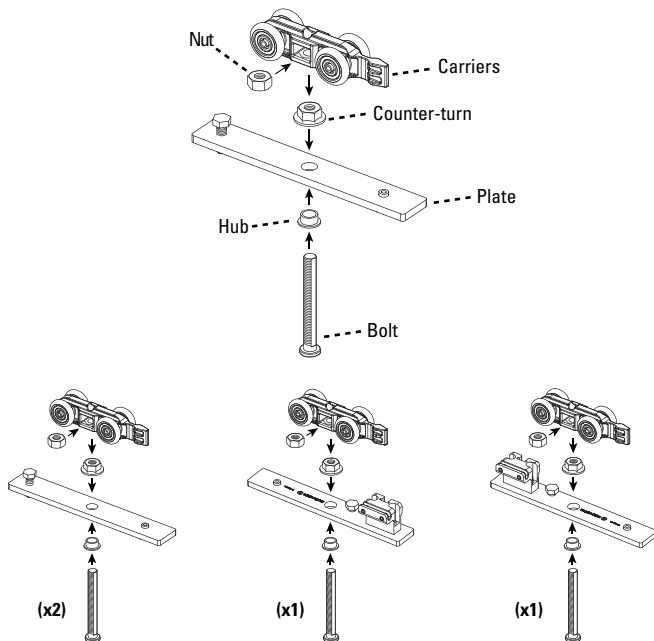

- Insert stoppers DN 80, carriers and pulley stoppers into the track, following the positions shown in the diagram.

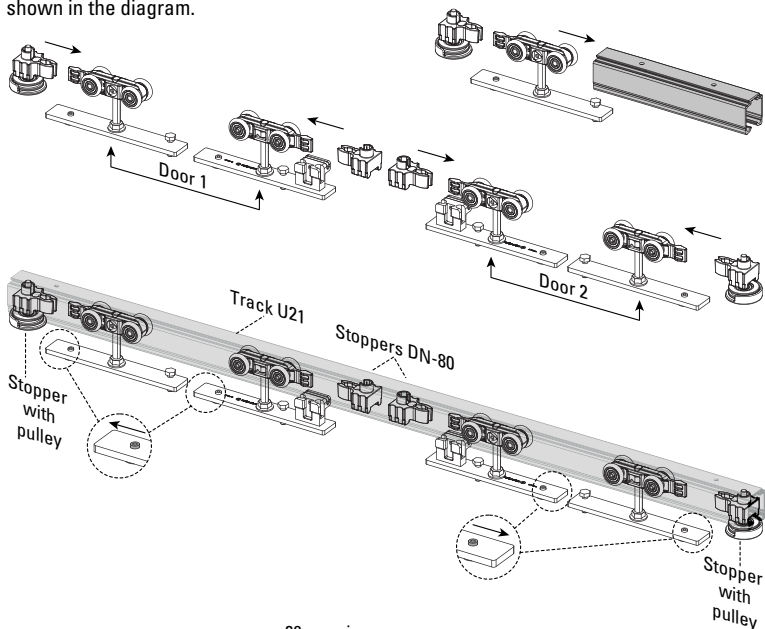

- Fix the tracks to the ceiling. Take into consideration the distance which is shown in the diagram. (Fixtures not included).

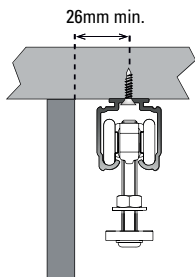

- After fixing, clean the track grooves to avoid possible leftover residues.

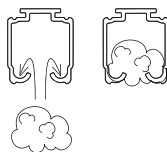

## Set-up of the guide to the floor

## step 2

- Plumb the track to determine the Floor guide VD position.

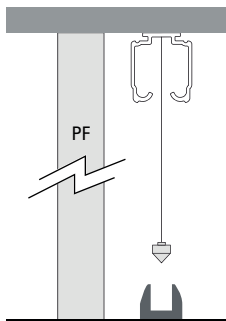

- Position the regulator in the Floor guide VD, according with the glass width to be used.

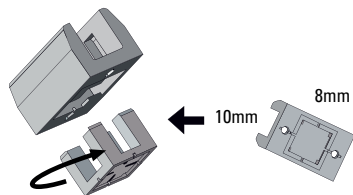

- Fix the guide to the floor at the bound of the fixed panel, as shown in the diagram, using dowels n°6 and then screws 3.5x35.

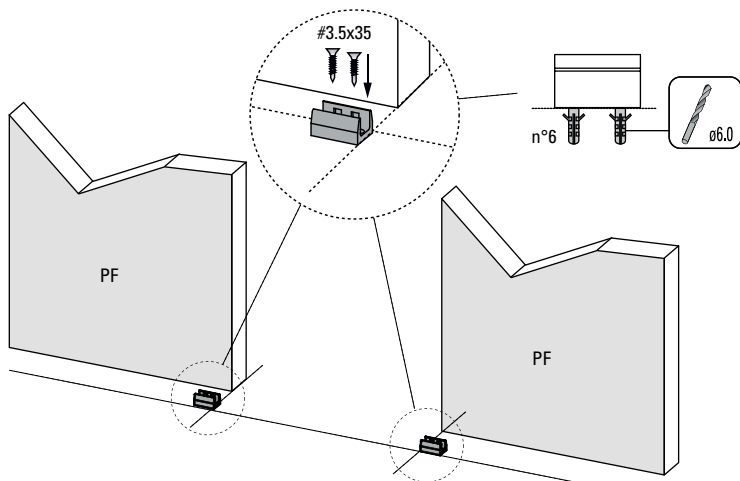

## step 3

OPTION (A): Perforated clamps / OPTION (B): Compression clamps

①

- (A) Set up the glass according to the indications on the diagram.

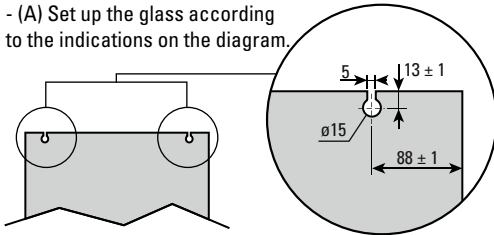

(B) Clean the glass in the clamp installation area using the cleaning kit included.

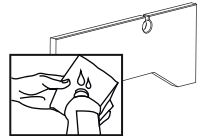

②

- (A) and (B) Place the spacer in the 8-10mm position.

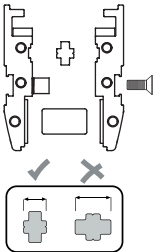

③

- (A) and (B) Place the clamp in the crystal, 6mm from the edge.  
- (A) Place the metal hub in the crystal.

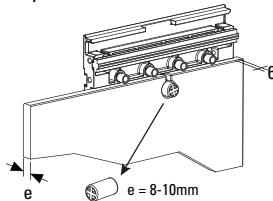

④

- (A) and (B) Place the other part of the clamp and tighten the bolts with the 4mm Allen key.

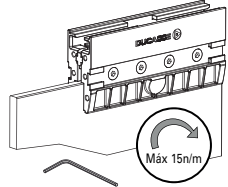

⑤

- (A) and (B) Place the adhesives on the edges.

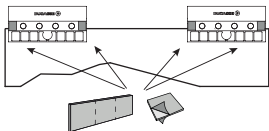

\*\*\* Clamps stoppers must be positioned at opposite sides.

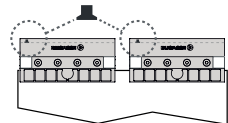

OPTION (A)

- \* Recommended for crystals over 50 kg.
- \* Consider perforations for the door handles.
- \* Recommended for high humidity conditions.

- Mount Door 1 (P1) on floor guide VD, making sure the telescopic guide is not damaged, and introduce the plates in the clamps.
- In the same way, mount the door 2 (P2) in guide VD as shown in the diagram.

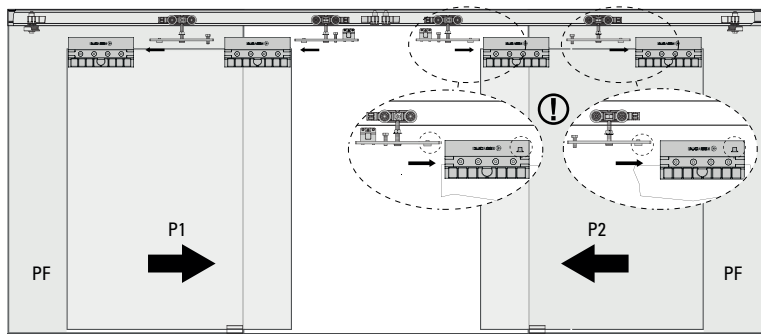
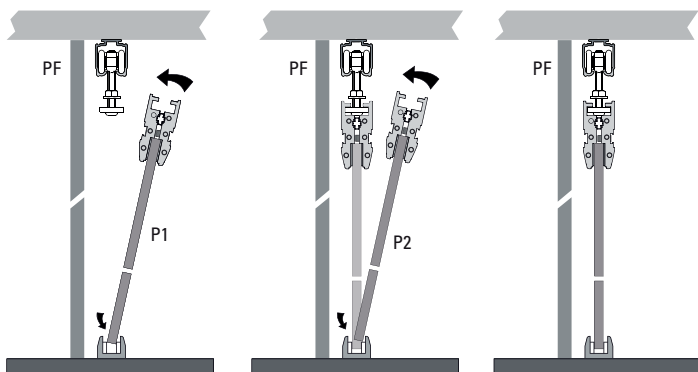

## step 5

- With the help of the Segmenta key, fix the carrier plates to the clamps, adjusting the upper bolt, as shown.

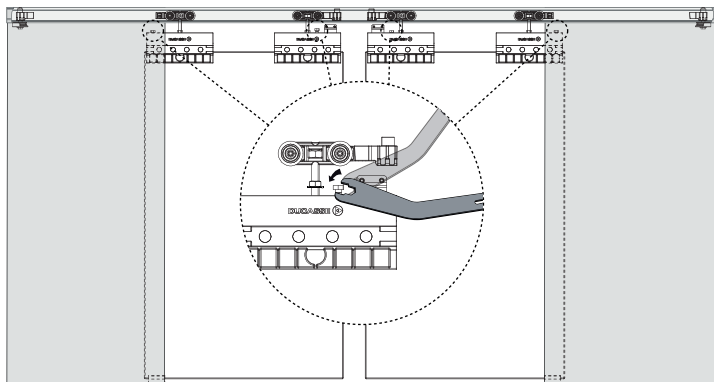

- Regulate the height of the glasses, adjusting the carrier bolt with the Segmenta key.

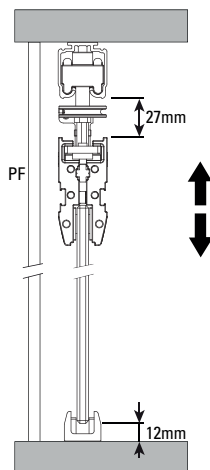
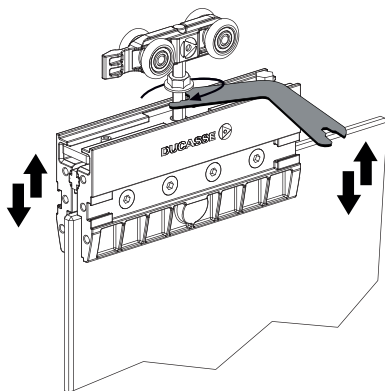



## Stoppers Set-up

step 6

- Keep the doors in a closed position and assemble carriers with stoppers DN 80 in the middle of the track. Define the desired door separation and mark the stoppers position.

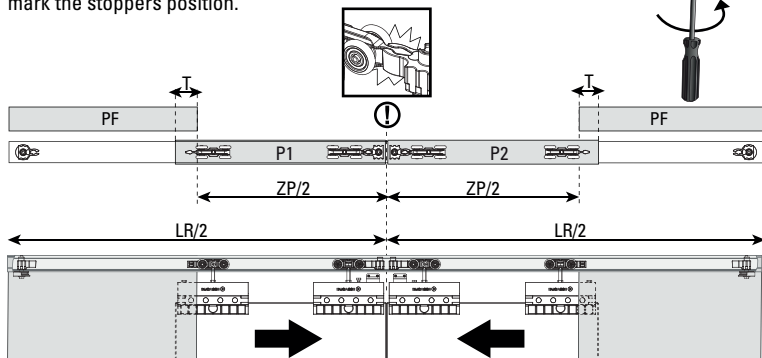

- Open the doors, disassemble the stoppers, take them to the mark and fix with the screwdriver as shown in the diagram.
- Move the pulley stoppers to the ends of the track and fix them using Segmenta key.

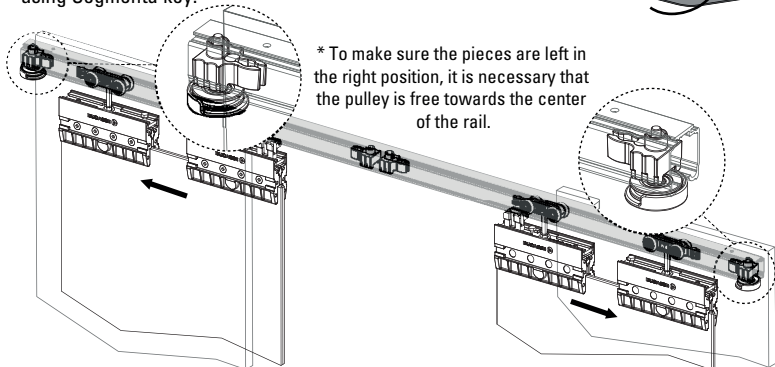
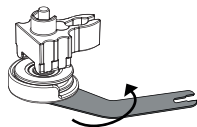

### step 7

- Place the cable around the pulleys, tighten the cable and then, fix its end in the cable locker using 2.5mm Allen key.

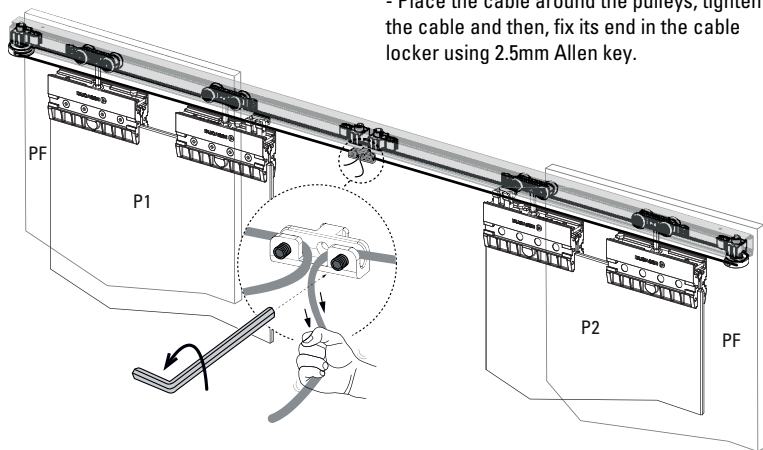

- Mount the cable locker with the cable in the cable base plate of the door 1 (P1), and then fix it with 2.5 mm Allen key.

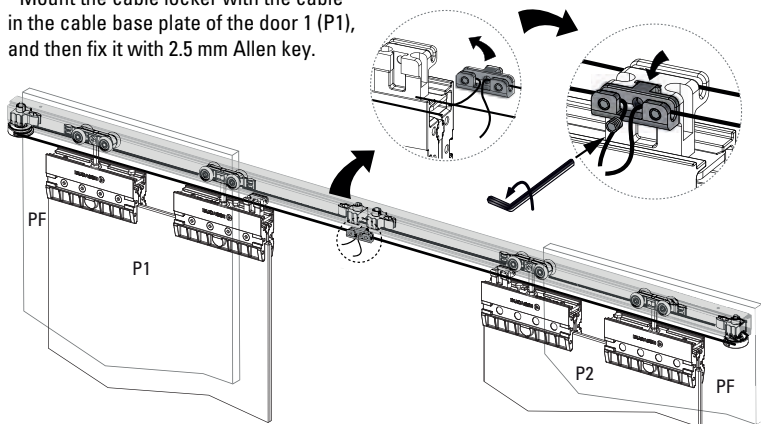

- Then, with the doors closed, place the cable in the cable base plate of door 2 (P2) using 2.5 mm Allen key.

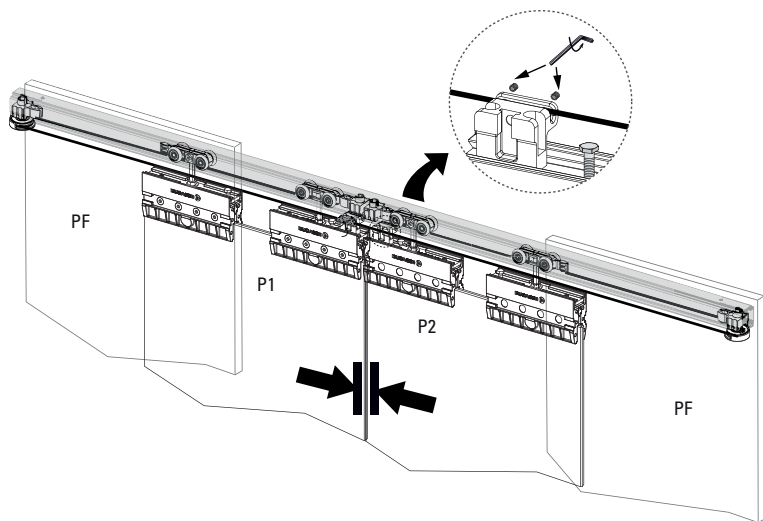

## step 8

- With the Segmenta key, lift the counterturn in order to be able to place the fascias in the next step.

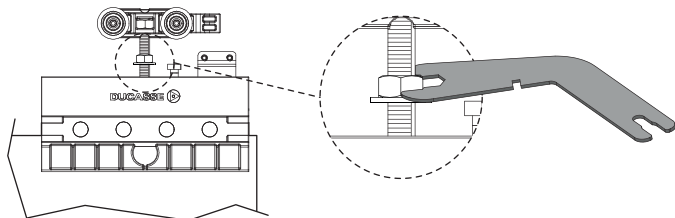

- Clip the fascia in the door clamps and then fix the right and left end caps on both sides, with M5 x 20 bolts and the 3mm Allen key.

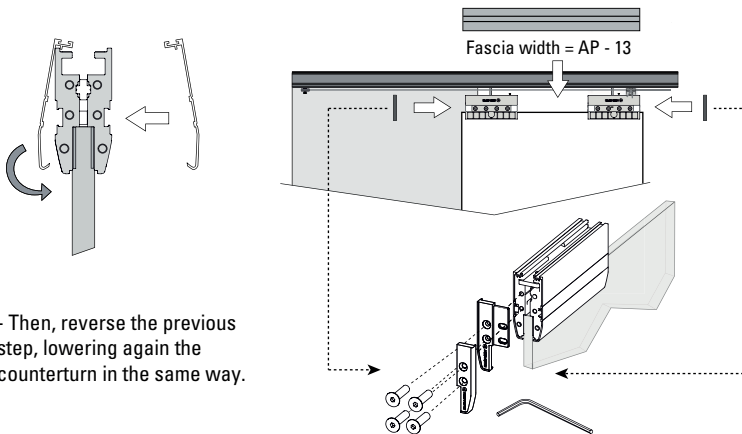

- Then, reverse the previous step, lowering again the counterturn in the same way.

## Accessories

- 1 FASCIA U-21 66x8
- 2 FASCIA U-21 120x8
- 3 END CAP FASCIA U-21 66x8
- 4 END CAP FASCIA U-21 120x8
- 5 ZAMAK END CAPS

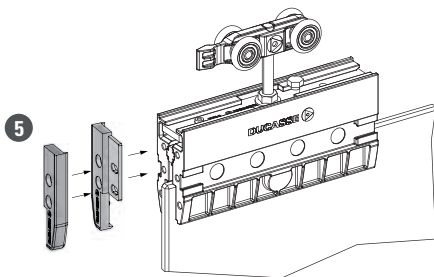
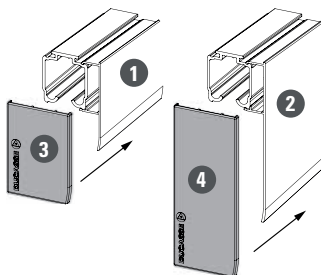

# índice

TWIN OP VD é um sistema correção sincronizado para portas de vidro, de até 80kg cada folha.

O sistema permite que com um só movimento se abram ambas as portas sincronizadamente em sentido oposto.

- 17 Dados gerais e dimensionamento das portas.
- 18 Detalhes de partes e peças.
- 19 Passo 1: Instalação de trilho, carros e freios.
- 21 Passo 2: Fixação da guia ao chão.
- 22 Passo 3: Armação das portas.
- 23 Passo 4: Montagem das portas.
- 24 Passo 5: Fixação das placas e regulagem de altura.
- 25 Passo 6: Fixação de freios.
- 26 Passo 7: Fixação do cabo.
- 28 Passo 8: Instalação das sanefas.
- 29 Acessórios.

mm	Polegadas	Fração
1	0.0394	3/64
2	0.0787	5/64
3	0.1181	1/8
4	0.1575	5/32

mm	Polegadas	Fração
5	0.1969	13/64
6	0.2362	15/64
7	0.2756	9/32
8	0.3150	5/16

mm	Polegadas	Fração
9	0.3543	23/64
10	0.3937	25/64
11	0.4375	7/16
12	0.4688	15/32

**\*TODAS AS MEDIDAS ESTÃO INDICADAS EM MILÍMETROS**

## Dados gerais e dimensionamento das portas



QUANTIDADE  
DE PORTAS



CAPACIDADE DE  
CARGA POR PORTA



PARA PORTAS  
DE VIDRO



ESPESSURA PORTA  
VIDRO



VÃO DE PASSAGEM



LARGURA DA  
PORTA

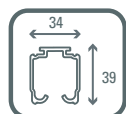

TRILHO U21  
PARA SANEFA

### Como dimensionar as portas

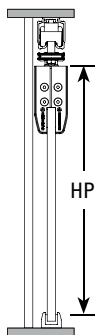
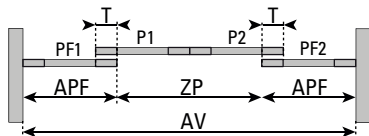
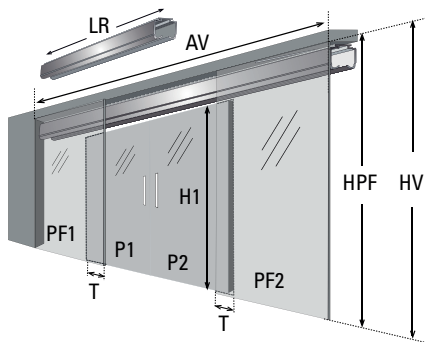

$$\begin{aligned} LR &= 4AP - 2T \\ AP &= (ZP/2) + T \\ H1 &= HV - 125 \\ APF &\geq AP \\ HPF &= HV \\ HP &= H1 + 51 \\ T &= 50 \text{ min.} \end{aligned}$$

**!** Usar com vidro temperado



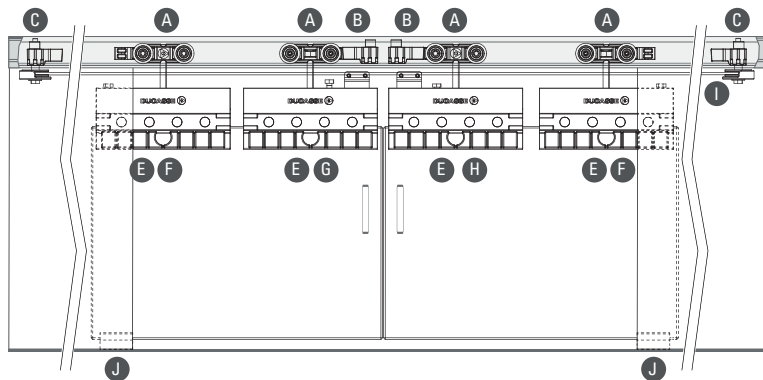

**AP = Largura Porta | AV = Largura Vão | H1 = Altura Vidro | HP = Altura Porta | HV = Altura Vão**  
**HPF = Altura Pannel Fixo | APF = Largura Pannel Fixo | ZP = Zona de Passagem**  
**LR = Comprimento Trilho | T = Sobreposição**

## Detalhes de partes e peças







### TWIN OP VD

<b>A</b>	Carro DN 80		4
<b>B</b>	Freios DN 80		2
<b>C</b>	Freios roldana		2
<b>D</b>	Parafuso carro		4
<b>E</b>	Mordaça superior		4
<b>F</b>	Placa Twin		2
<b>G</b>	Placa candado cabo direita		1
<b>H</b>	Placa candado cabo esquerda		1
<b>I</b>	13mts cabo + fixador cabo		1
<b>J</b>	Guia VD + espaçador 8-10		2
<b>K</b>	Tampa mordaça esquerda		4
<b>L</b>	Tampa mordaça direita		4
<b>M</b>	Chave Segmenta		1
<b>N</b>	Chave Allen 2.5 / 3 / 4mm		1

<b>O</b>	Parafusos M5 x 20		16
<b>P</b>	Buchas n°6		2
<b>Q</b>	Parafusos #3.5 x 35		2
<b>R</b>	Kit de limpeza		4

### FERRAMENTAS NECESSÁRIAS

Furadeira	
Torquimetro	
Prumo	
Chave Phillips	
Trena	



- Cortar os trilhos conforme a fórmula indicada e perfurar.

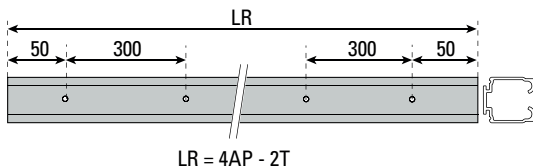

- Armar os conjuntos de carros, introduzindo os parafusos através das placas e dos carros, prestando atenção especial na posição dos mesmos.

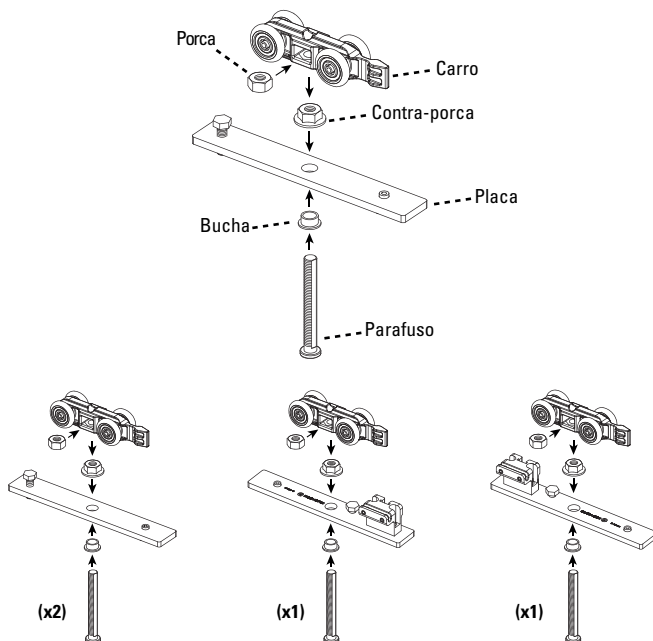

- Introduzir no trilho: os freios DN80, os carros e os freios polia, nas posições indicadas no desenho.

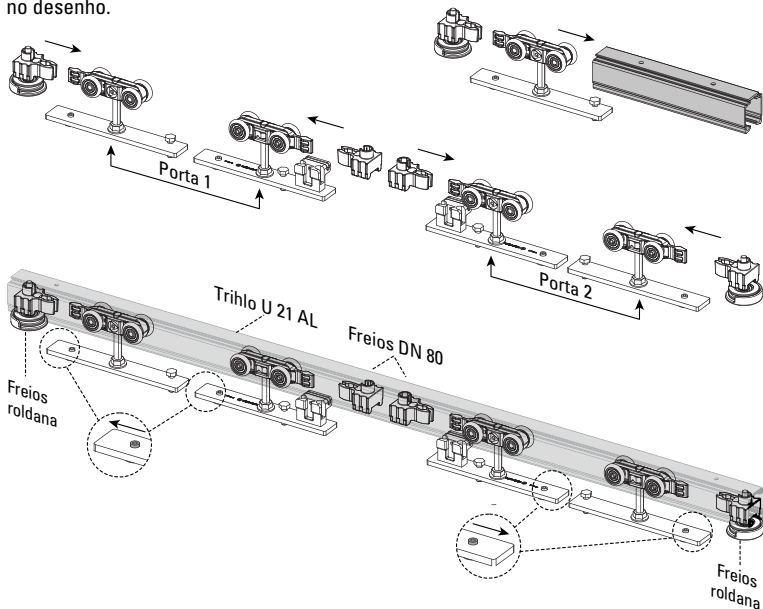

- Fixar o trilho superior, considerando a distância indicada no esquema. (Fixações não incluídas).

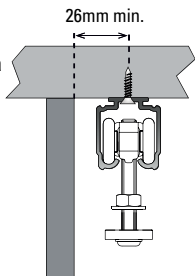

- Depois de fixar, limpar as pistas do trilho para evitar possíveis resíduos.

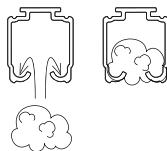

## Fixação das guias ao chão

## passo 2

- Usar prumo no trilho, para determinar a posição das Guias VD.

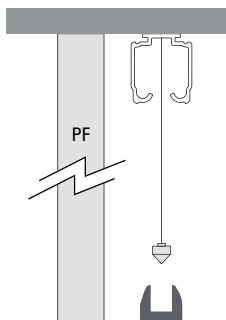

- Posicionar o regulador na Guia VD, segundo a espessura do vidro que se utilize.

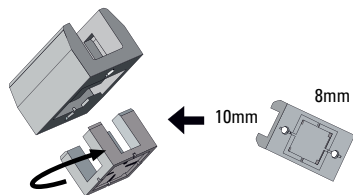

- Fixar as guias ao chão, utilizando as buchas nº6 e depois os parafusos 3.5x20.

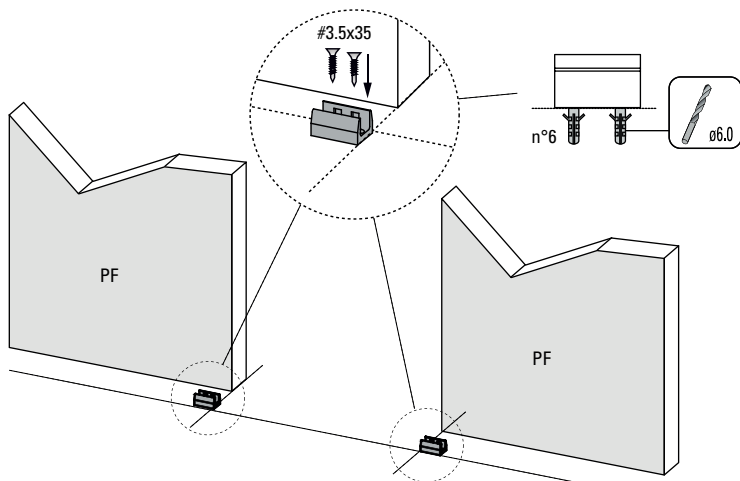

passo 3

OPÇÃO (A): Mordças perfuradas / OPÇÃO (B): Mordças à pressão

①

- (A) Usinar o vidro conforme as indicações do desenho

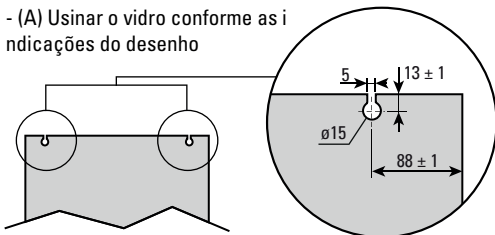

(B) Limpar o vidro na zona de instalação da mordça com o kit de limpeza incluído.

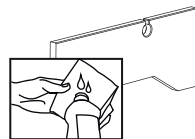

②

- (A) e (B) colocar o distanciador na posição 8-10mm.

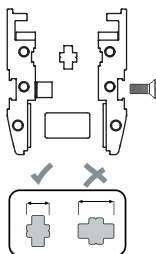

③

- (A) e (B) Posicionar a mordça no vidro (B) a 6mm da borda.  
- (A) Colocar a bucha no vidro.

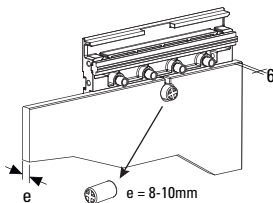

④

- (A) e (B) Colocar a outra parte da mordça e apertar os parafusos com a chave Allen 4mm.

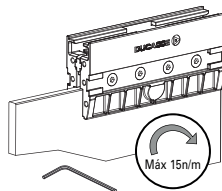

⑤

- (A) e (B) Colocar os adesivos nos extremos da mordça.

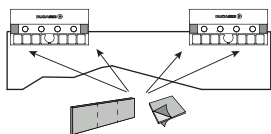

\*\*\* Os topes das mordças devem ficar posicionadas para lados opostos

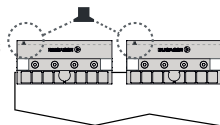

OPÇÃO (A)

- \* Recomendada para portas acima de 50kg.
- \* Prever as furações para puxadores.
- \* Recomendada para locais com umidade elevada.

- Montar a porta 1 (P1) sobre a guía VD, cuidando de não danificar a guía telescópica, e introduzir as placas nas mordças.
- Da mesma forma montar a porta 2 (P2) sobre a outra guía VD, como se mostra no desenho.

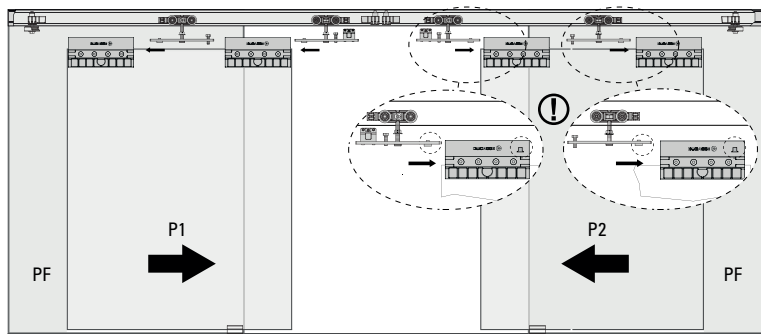
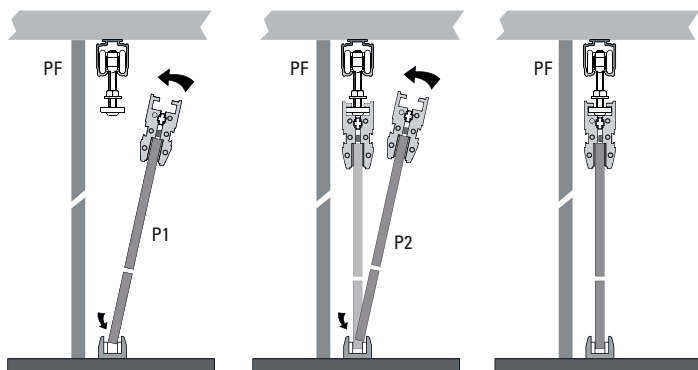

### passo 5

- Com a ajuda da chave Segmenta, fixar as placas dos carros nas mordças, ajustando o parafuso superior, como se indica.

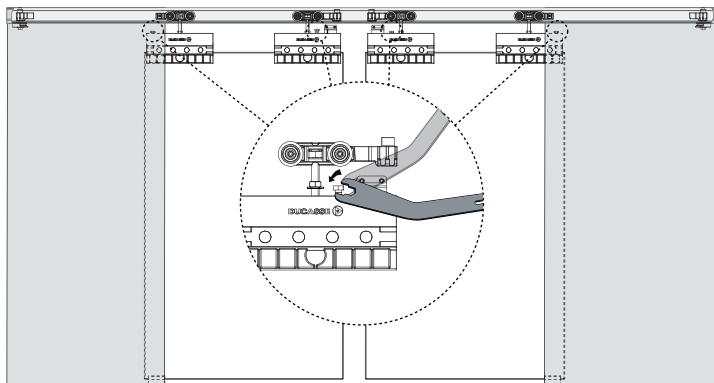

- Regular a altura dos vidros, ajustando o parafuso do carro com a chave Segmenta.

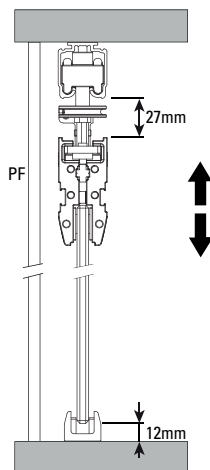
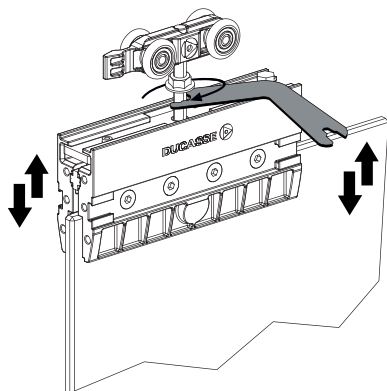

- Movimentar as portas para suas posições fechadas e encaixar os carros nos freios DN80, no meio do trilho. Separar as portas da forma desejada e marcar a posição dos freios.

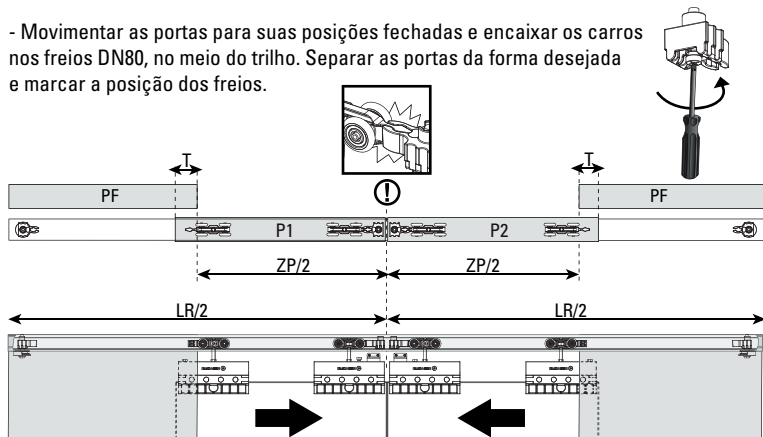

- Abrir as portas, desclipe os carros dos freios, posicionar os freios nas marcas e fixa-los, como demonstra o desenho.
- Posicionar os freios polia nos extremos do trilho e fixa-los com a chave segmenta.

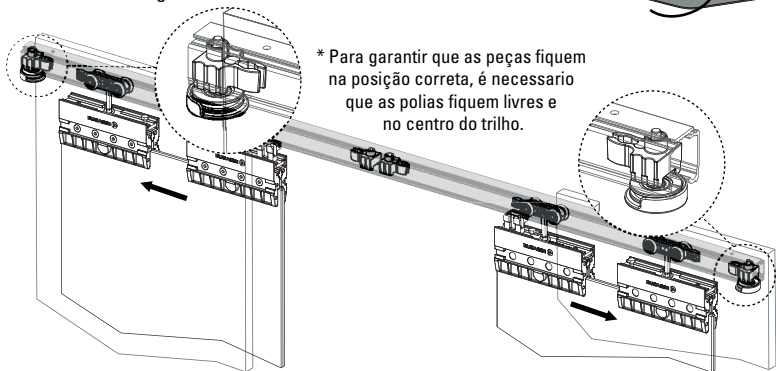
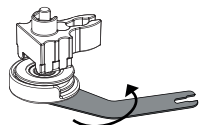

\* Para garantir que as peças fiquem na posição correta, é necessário que as polias fiquem livres e no centro do trilho.

passo 7

- Passar a corda ao redor das polias, tensionar e fixar a ponta no fecho candado com a chave allen 2.5mm.

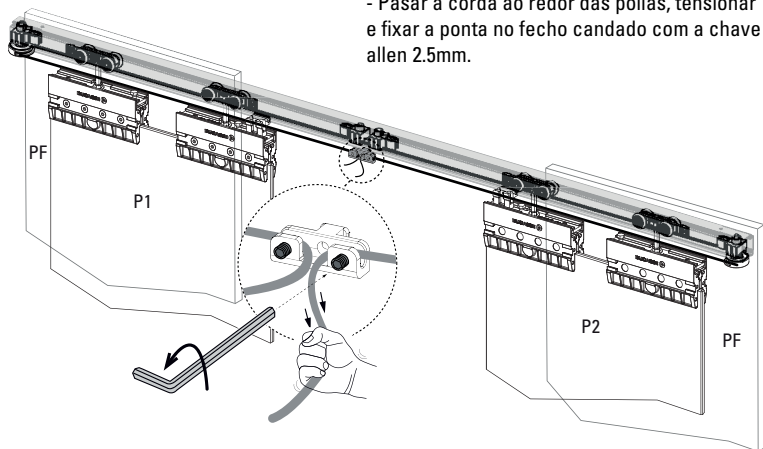

- Montar o fecho candado com a corda na base candado da porta 1 (P1), após fixar a corda com a chave Allen 2.5mm.

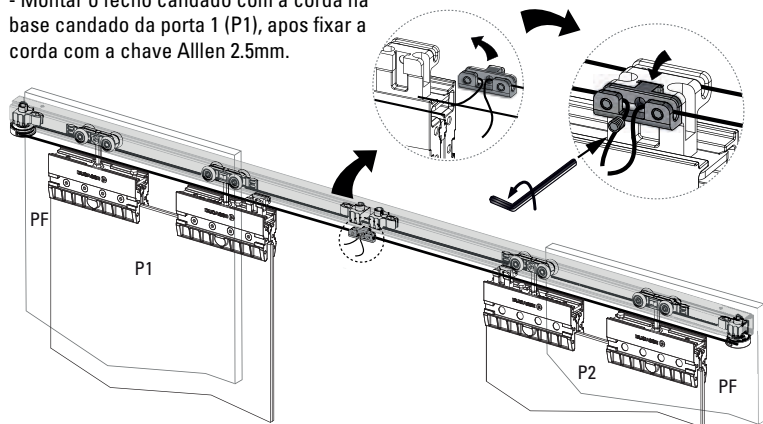



- Após, com as portas fechadas, fixar a corda na base candado da porta 2 (P2) com a chave allen 2.5mm.

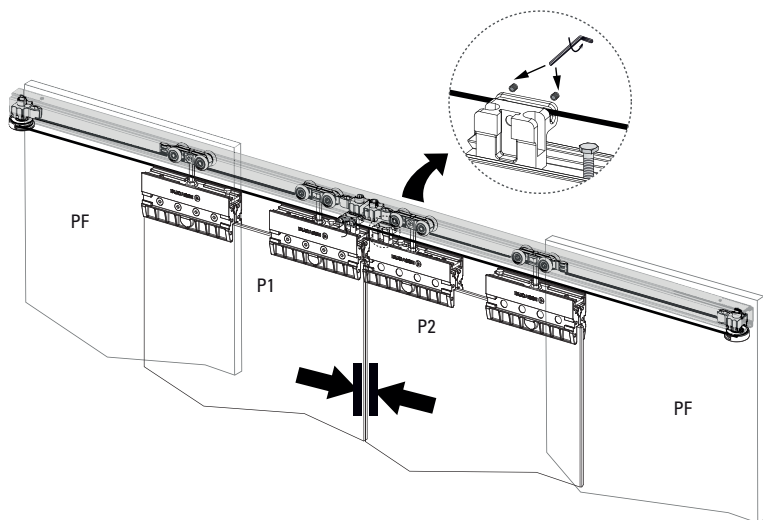

## passo 8

- Com a chave Segmenta, subir a contra-porca para poder colocar as sanefas no passo seguinte.

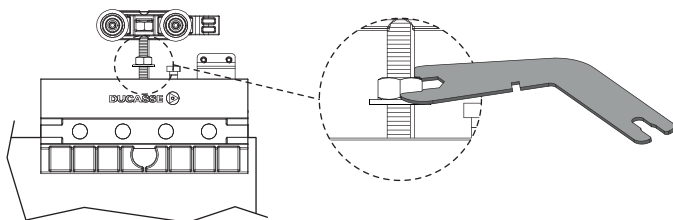

- Clipar as sanefas nas mordanças da porta, e após fixar as tampas direitas e esquerdas por ambos os lados, com parafusos M5 x 20 e a chave Allen 3mm.

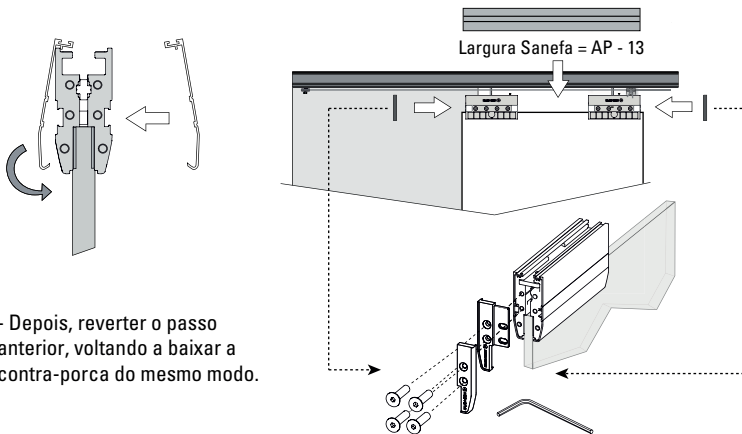

- Depois, reverter o passo anterior, voltando a baixar a contra-porca do mesmo modo.

## Acessórios

**1 SANEFA U-21 66x8**

**2 SANEFA U-21 120x8**

**3 TAMPA U-21 SANEFA 66x8**

**4 TAMPA U-21 SANEFA 120x8**

**5 TAMPA MORDAÇA ZK**

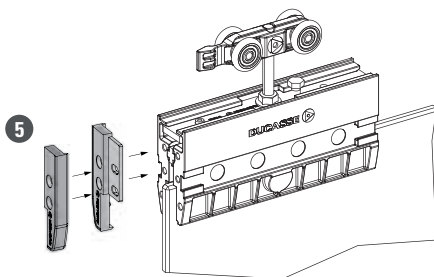
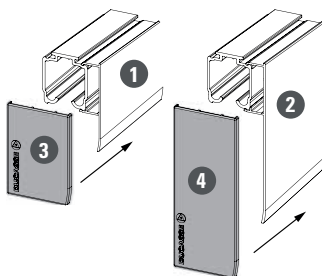

**DUCASSE**   
INDUSTRIAL

[www.ducasseindustrial.com](http://www.ducasseindustrial.com)

LINEA  
SEGMENTA