

# Guía GOR

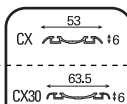

## Componentes

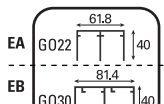
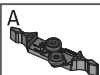

Perfil GO 22/30  
Perfil GO 22/30

Riel AL Doble CX / CX30  
Trilho Duplo CX / CX30  
Double Carrier Track CX / CX30

Riel Embutido CX  
Trilho Embutido CX  
Inrail Carrier Track CX

Riel AL CD 50 CX  
Trilho CD 50 CX  
Carrier Track CD 50 CX



	HP = H1 - 40
	HP = H1 - 40 E máx. = 22
	HP = H1 - 40 E máx. = 30
	HP = H1 - 35

$$AP = AV/2 + 25$$

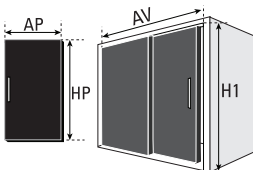

Todas las medidas expresadas en milímetros

Todas as medidas estão em milímetros.

All measurements in millimeters.

mm	Decimal inches	Aprox Fraction	mm	Decimal inches	Aprox Fraction
1	0.0394	3/64	6	0.2362	15/64
2	0.0787	5/64	7	0.2756	9/32
3	0.1181	1/8	8	0.3150	5/16
4	0.1575	5/32	9	0.3543	23/64
5	0.1969	13/64	10	0.3937	25/64

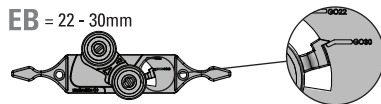
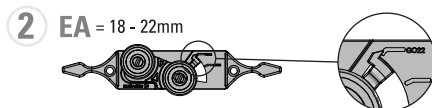
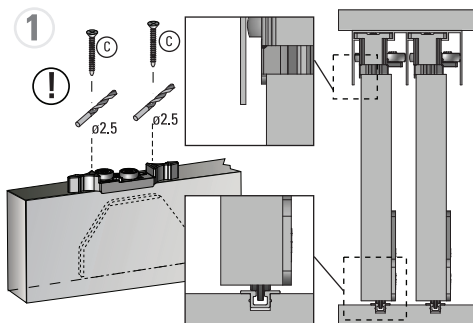

**3** Instalar los frenos antes de fijar la guía al mueble.

Freio deve ser instalado no perfil guia anteriormente à colocação do mesmo no móvel.

Insert the stoppers into the profile before installation.

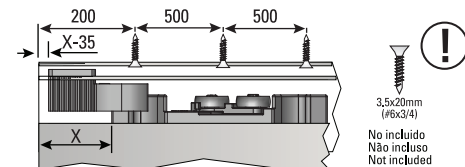

X min. = 35

3,5x20mm  
(#6x3/4)

Not included  
Não incluso  
Not included

4

4.a



Perfil GO 22  
Profile GO 22



Perfil GO 30  
Profile GO 30



Riel Embutido CX  
Triho Embutido CX  
Inlaid Carrier Track CX

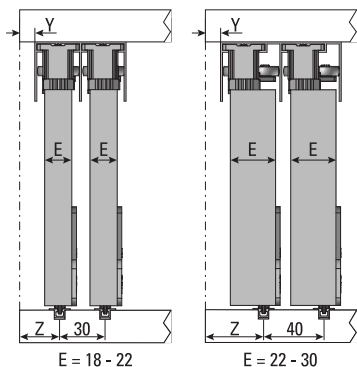
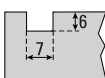

E	Z
18	Y + 16.5
20	Y + 18.5
22	Y + 20.5
25	Y + 23.5
30	Y + 28.5

4.c



Perfil GO 30  
Profile GO 30



Riel AL Doble CX30  
Triho Duplo CX30  
Double Carrier Track CX30

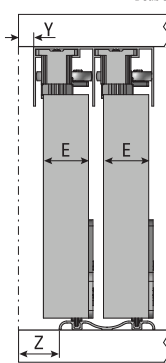

E	Z
22	Y + 9
25	Y + 12
33	Y + 17

4.b



Perfil GO 22  
Profile GO 22



Riel AL Doble CX  
Triho Duplo CX  
Double Carrier Track CX

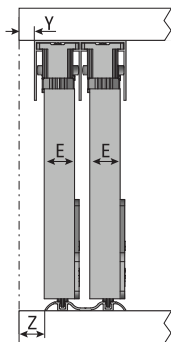

E	Z
18	Y + 5
20	Y + 7
22	Y + 9

4.d



Perfil GO 22  
Profile GO 22



Perfil GO 30  
Profile GO 30



Riel AL CD 50 CX  
Triho CD 50 CX  
CarrierTrack CD 50 CX

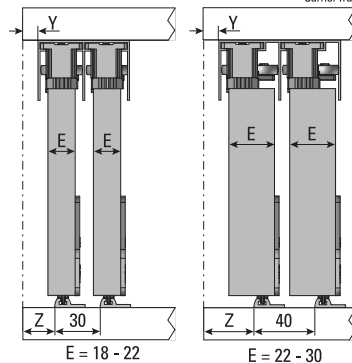

E	Z
18	Y + 11
20	Y + 14
22	Y + 16
25	Y + 19
30	Y + 24