

# CD 30 CX

Madera / Madeira / Wood



Peso puerta  
Peso porta  
Door weight



Una puerta  
Uma porta  
One door

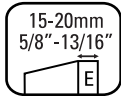

Espesor Madera  
Espessura Madeira  
Wood Thickness



Ancho mínimo  
Largura mínima  
Minimum width



Altura máx. puerta  
Altura max. porta  
Max. Door height

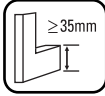
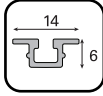

Riel Embutido CX  
Trilho Embutido CX  
Inlay Carrier Track

COMPONENTES / COMPONENTES / COMPONENTS

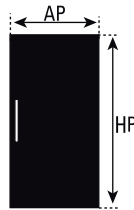
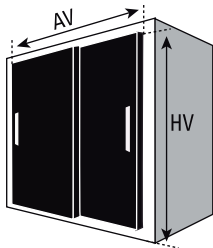
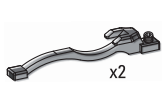
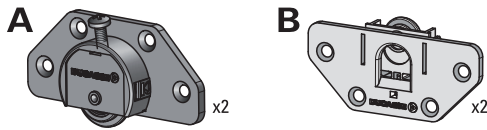

AV = Ancho de vano  
HV = Altura de vano  
AP = Ancho de puerta  
HP = Altura de puerta

$HP = HV - 8$

$AP = AV/2 + 25$

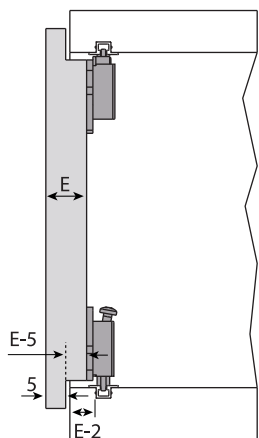
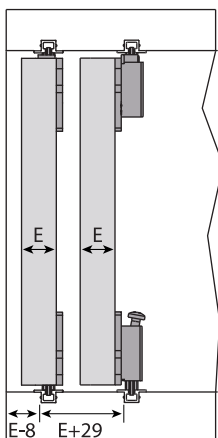
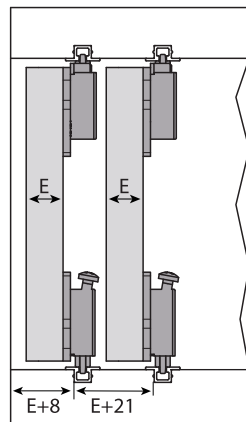
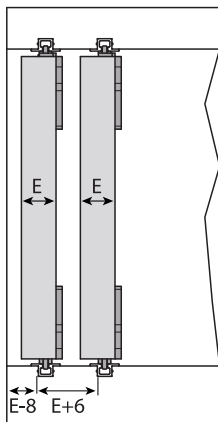

## 1

1.1

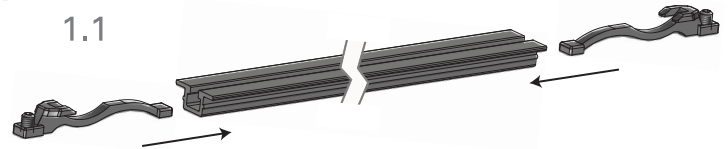

1.2

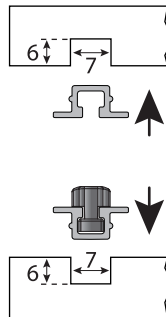

1.3

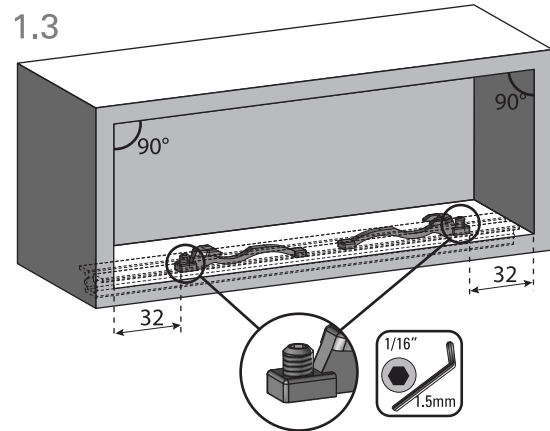

## 2 Embutido / Embutido / Inlay

2.1

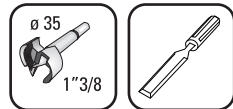
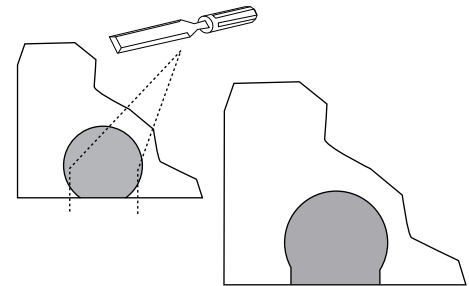
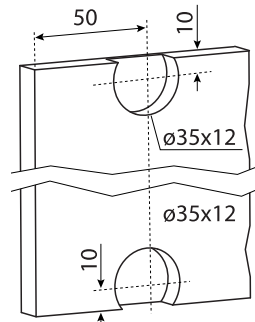

2.2

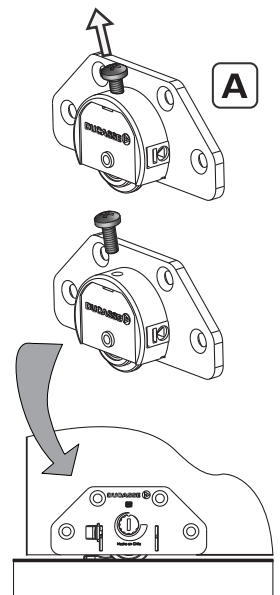
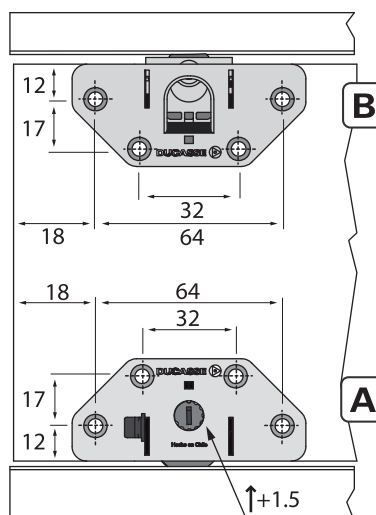
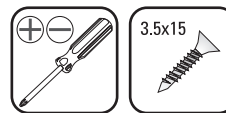

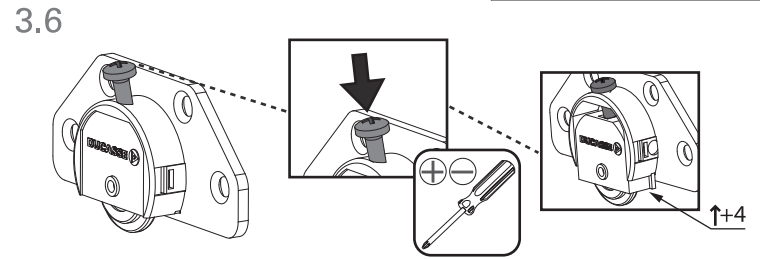
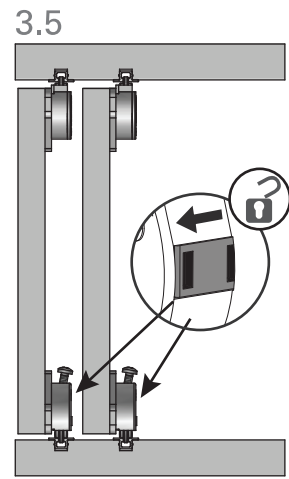
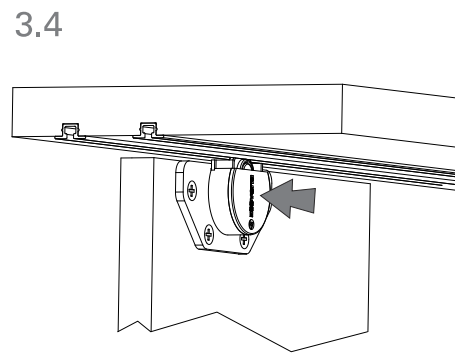
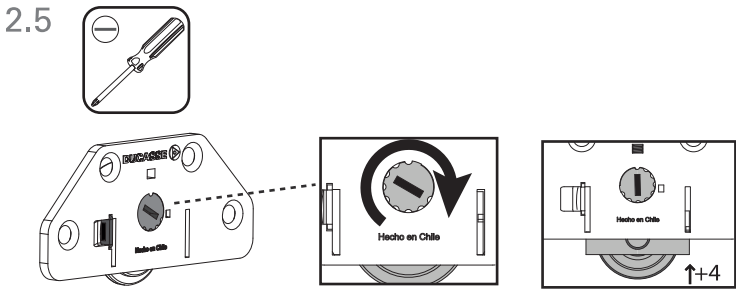
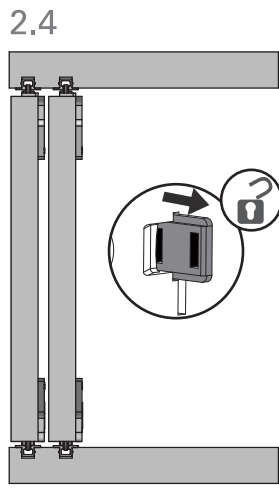
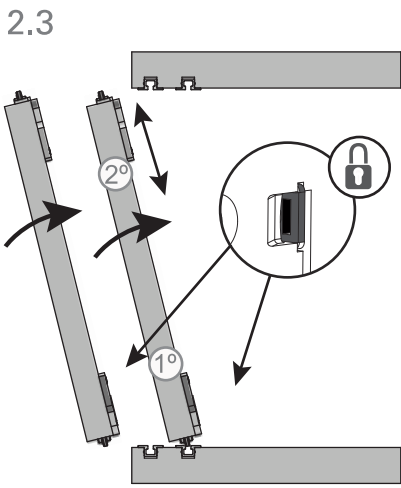

3 Sobrepuesto / Sobreposto / Overlay

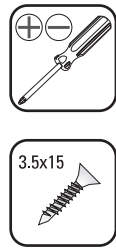
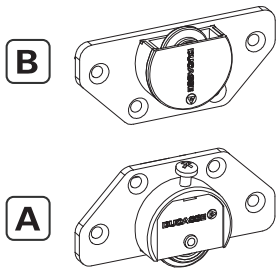

\* Accesorios / Accessories

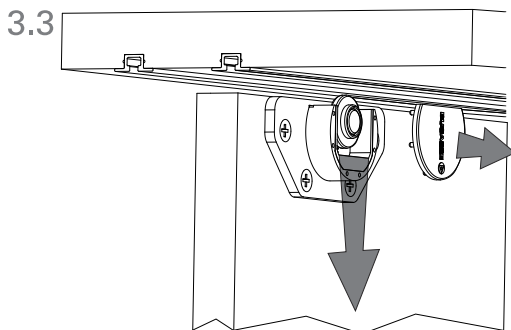
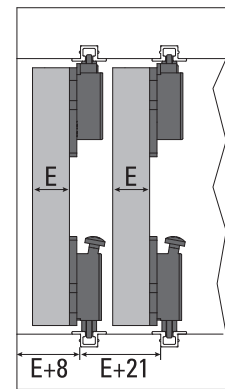
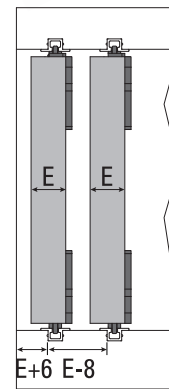
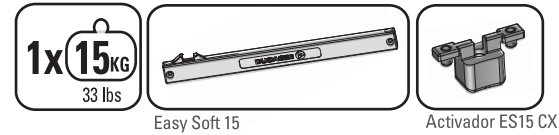
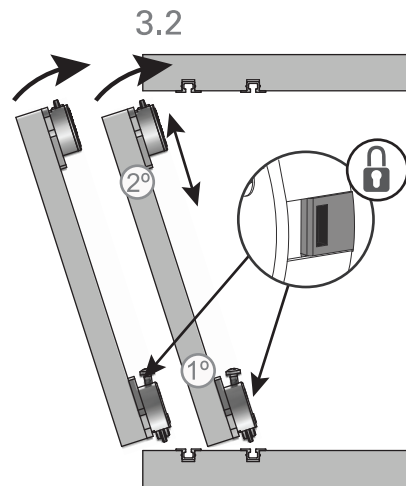
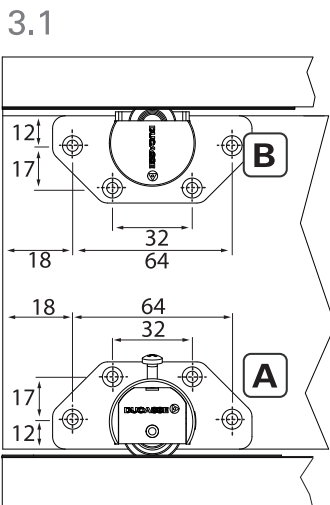
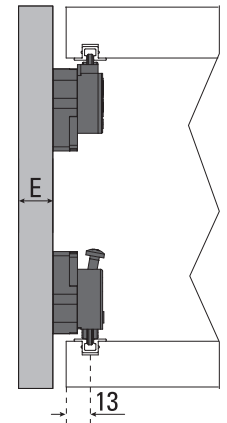
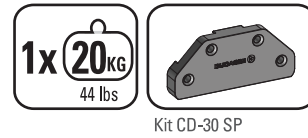

Todas las medidas expresadas en milímetros  
 Todas as medidas estão em milímetros.  
 All measurements in millimeters.

mm	Decimal inches	Aprox Fraction	mm	Decimal inches	Aprox Fraction
1	0.0394	3/64	6	0.2362	15/64
2	0.0787	5/64	7	0.2756	9/32
3	0.1181	1/8	8	0.3150	5/16
4	0.1575	5/32	9	0.3543	23/64
5	0.1969	13/64	10	0.3937	25/64