



CANTIDAD  
DE PUERTAS



SISTEMA  
DENTRO DE VANO



CAPACIDAD DE  
CARGA POR HOJA



ESPESOR  
DE PUERTA



ANCHO  
DE PUERTA



LUZ  
RIEL / PUERTA



RODAMIENTO



RESISTENCIA CÁMARA  
NIEBLA SALINA



DN80 SR



Carretilla colgante sin freno para puertas de paso con sistema de montaje frontal.

### USOS

- | Puertas de bodegas
- | Puertas de paso interior

### CUALIDADES

- | La geometría de su placa de montaje permite insertar el perno de manera frontal, facilitando su instalación.
- | La placa de montaje se puede apernar o soldar.
- | Posee guía al piso que mantiene la puerta alineada.
- | Producto de alta duración y excelente comportamiento en el uso reiterado.



MATERIAL  
PUERTA



ANSI - BHMA  
UNE - EN

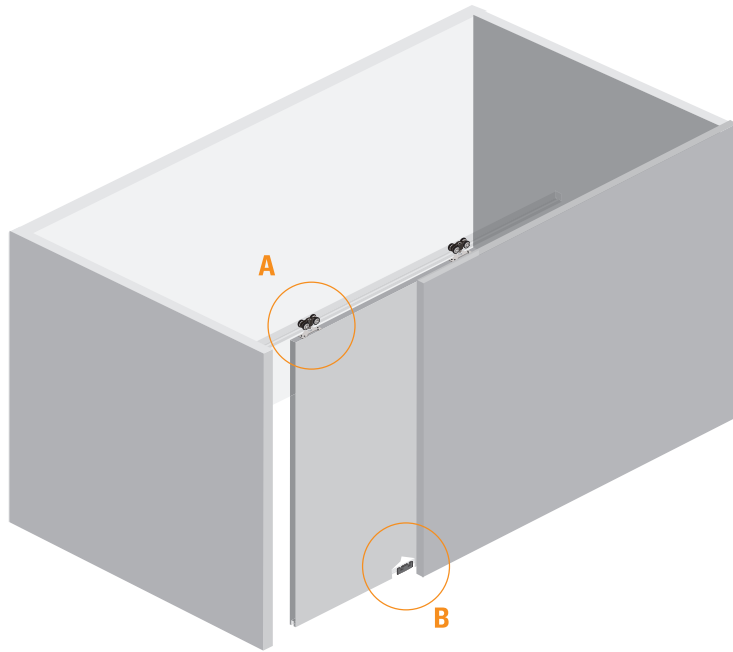

Vista Frontal

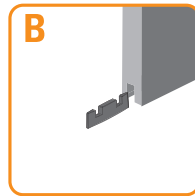
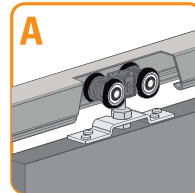

Vista Lateral  
Riel U 100

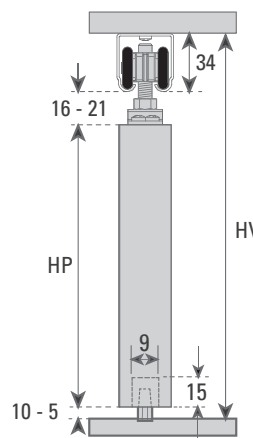
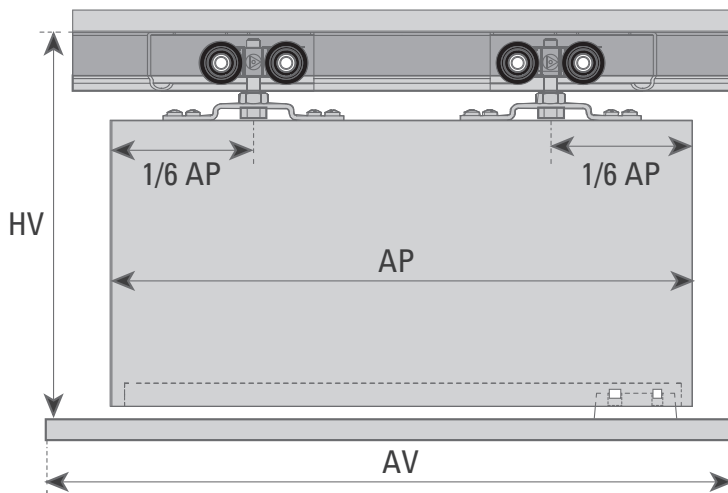

$$HP = HV - 60$$

AP = Ancho de Puerta | HP = Altura Puerta | HV = Altura Vano

DN80 SR

| para 1 Hoja |

10100217451

Mínimo de despacho: 10 unidades

**A** 2 Carros DN80 SR



**B** 1 Guía GP-16



**C** 2 Placas de montaje



**D** Tornillos



SE USA CON:



RIEL U-21 ESTANDAR AL  
2.0 m. 54033520024  
3.0 m. 54033530024  
6.0 m. 54033560024



RIEL U-100 ACERO  
2.0 m. 10100612020  
3.0 m. 10100612030