



CANTIDAD  
DE PUERTAS



MONTAJE  
DE PUERTA



MONTAJE  
DE CARRO

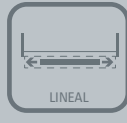

MOVIMIENTO  
DEL SISTEMA



CAPACIDAD DE  
CARGA POR HOJA



ANCHO DE  
PUERTA



ESPESOR  
DE PUERTA



MATERIAL DE  
PUERTA

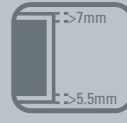

LUZ  
SUPERIOR | INFERIOR

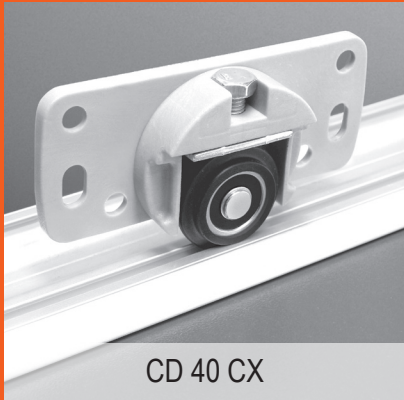

Sistema corredizo embutido para puertas de closet traslapables de hasta 40 Kg. por hoja.

### USOS

- | Puertas de madera y aluminio
- | Puertas de closet

### CUALIDADES

- | Fácil instalación.
- | Guía superior con freno.
- | Fácil regulación.
- | Suavidad de rodadura.
- | El carro se monta embutido, para una mínima separación entre puertas.



PERFORACIONES



TIPO DE  
RODAMIENTO



RESISTENCIA  
A LA CORROSIÓN



NORMA  
ANSI - BHMA



NORMA  
UNE - EN

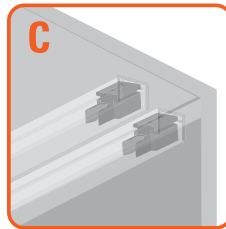
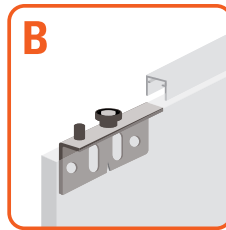
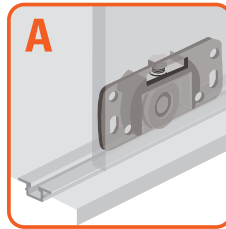
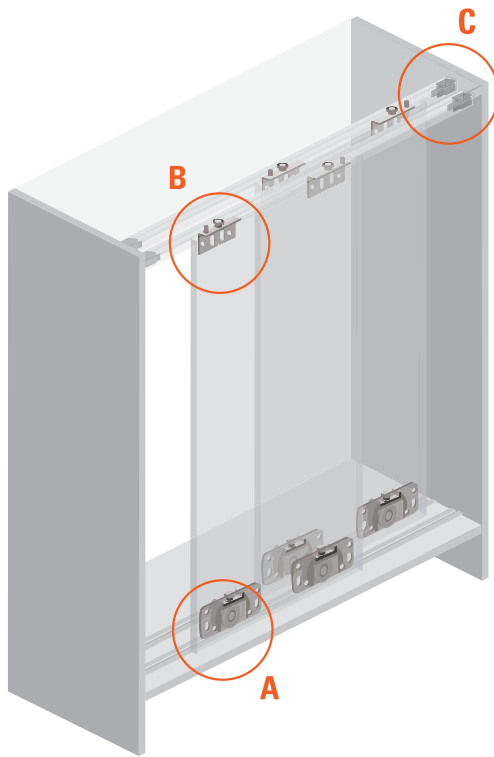

Vista Frontal

Vista Lateral

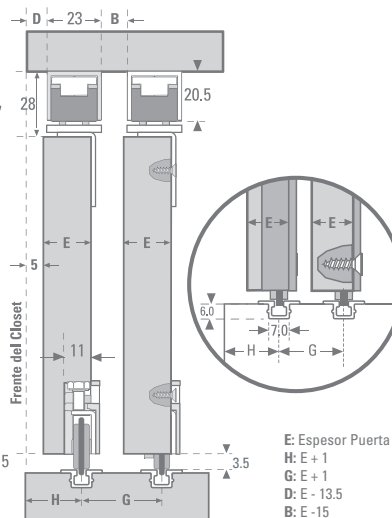
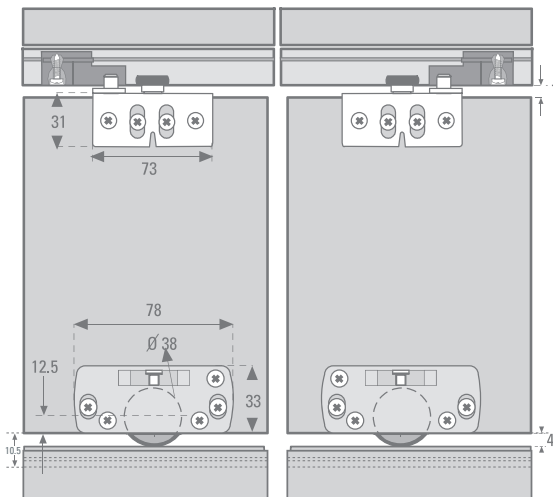

CD 40 CX  
| para 2 Hojas |

10100106540

- A** 4 Carros CD 40 CX
- B** 4 Guías Superiores
- C** 4 Frenos
- D** 4 Seguros
- E** 1 Llave M5
- F** Fijaciones

SE USA CON:



PERFIL GUÍA CANAL CD 50 AL  
 2m. 51030320024  
 3m. 51030330024  
 6m. 51030360024



1 RIEL SIMPLE EMBUTIDO CX AL  
 2m. 51031320024  
 3m. 51031330024  
 6m. 51031360024



2 RIEL SIMPLE SOBREPUESTO CX  
 2m. 51030820024  
 3m. 51030830024  
 6m. 51030860024



3 RIEL DOBLE CX 30 AL (esp. máx. 32)  
 2m. 51033030024  
 3m. 51033020024  
 6m. 51033060024