



CANTIDAD DE PUERTAS



SISTEMA DENTRO DE VANO



CAPACIDAD DE CARGA POR HOJA



ESPESOR DE PUERTA



ALTURA MÍNIMA PERFIL ALUMINIO



ALTURA MÍNIMA PERFIL ALUMINIO



RODAMIENTO



MATERIAL PUERTA



Carro D 30



Riel D 30 AL



Riel D 30 PVC



Sistema corredizo al piso, para puertas pequeñas de hasta 30 Kg.

USOS

- | Puertas de closets.
- | Puertas de muebles de tamaño medio.

CUALIDADES

- | Fácil instalación.
- | El carro puede instalarse embutido o sobrepuesto.
- | Posee una pestaña de refuerzo que permite la instalación con madera de menor calidad entregándole mayor soporte a la puerta.
- | Permite utilizar el mismo riel en la parte superior e inferior del vano.



RESISTENCIA CÁMARA
NIEBLA SALINA

D 30
| para 1 Puerta |

10100117100

A 2 Carros D 30

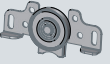

B 2 Frenos D 30



C 2 Guías D 30



Fijaciones

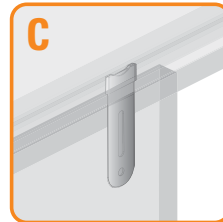
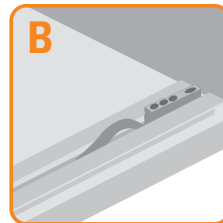
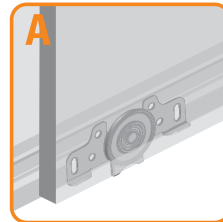
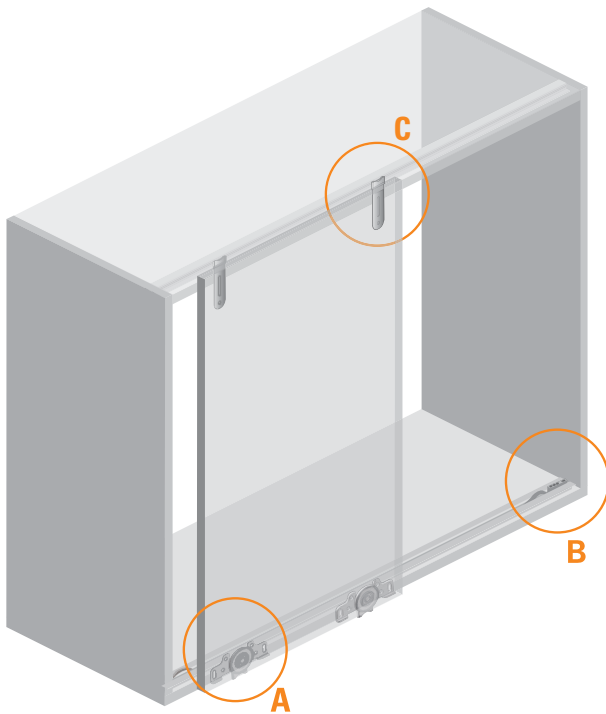

Vista Frontal

Vista Lateral

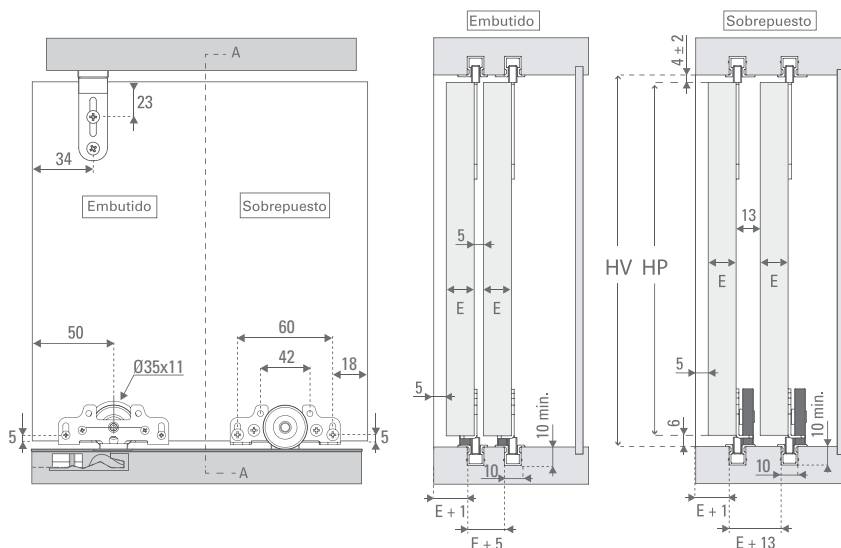

HV = Altura vano | HP = Altura puerta



RIEL D 30 AL

2.0 m. 51041020024

3.0 m. 51041030024

6.0 m. 51041060024