

AL 1540



Peso máx. puerta
Peso max. porta
Max. Door weight



Una puerta
Uma porta
One door

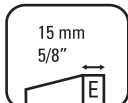

Espeor Madera
Espessura Madeira
Wood Thickness

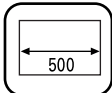

Ancho mínimo
Largura mínima
Minimum width

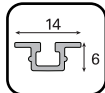

Riel Embutido CX
Trilho Embutido CX
Inlaid Carrier Track CX

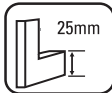

COMPONENTES / COMPONENTES / COMPONENTS

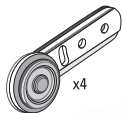

A(x12)- #6x1/2"

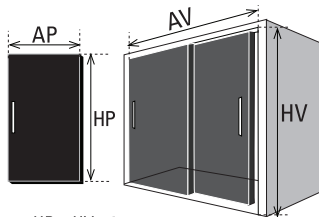

$$HP = HV - 4$$

$$AP = AV/2$$

1

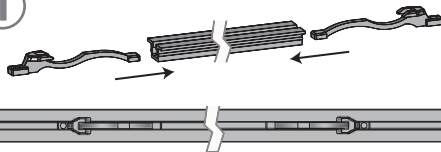

2

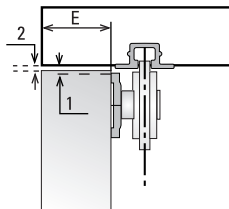

E	X
15 mm	19 mm
18 mm	22 mm
20 mm	23 mm

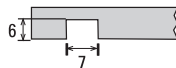
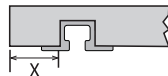

3

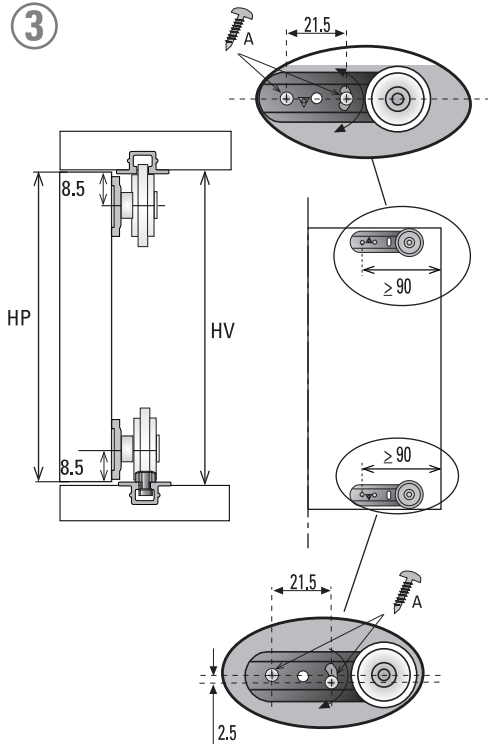

4

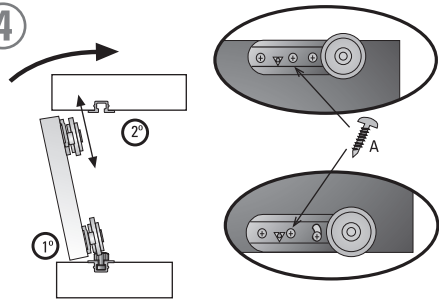

*

Accesorios / Accessories



Easy Soft 15



Activador ES15 CX

Todas las medidas expresadas en milímetros

Todas as medidas estão em milímetros.

All measurements in millimeters.

mm	Decimal inches	Aprox Fraction	mm	Decimal inches	Aprox Fraction
1	0.0394	3/64	6	0.2362	15/64
2	0.0787	5/64	7	0.2756	9/32
3	0.1181	1/8	8	0.3150	5/16
4	0.1575	5/32	9	0.3543	23/64
5	0.1969	13/64	10	0.3937	25/64

V08.04.22
OP

