

DN-80 PL 2 Hojas



Peso máx. puerta
Peso max. porta
Max. Door weight



Dos puertas
Duas portas
Two doors

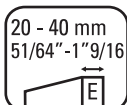

Espesor Madera
Espessura Madeira
Wood Thickness

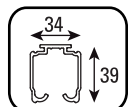

Riel U21
Trilho U21
Track U21 ST



Riel U100
Trilho U100
Carrier track U100

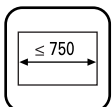

Ancho puertas
Largura portas
Doors width

COMPONENTES / COMPONENTES / COMPONENTS

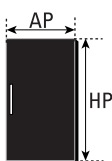
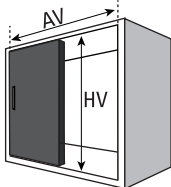
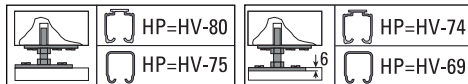
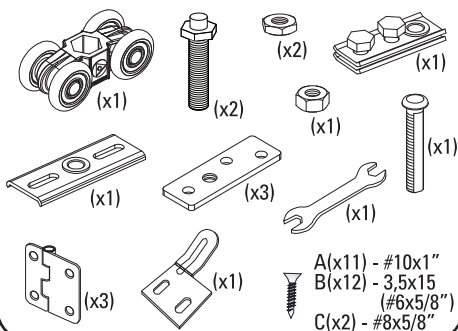

e	F
20/22/25	6
30/33	8
35/38	10
40	12

$$AP = (AV - F) / 2$$

mm	Decimal inches	Aprox Fraction	mm	Decimal inches	Aprox Fraction
1	0.0394	3/64	6	0.2362	15/64
2	0.0787	5/64	7	0.2756	9/32
3	0.1181	1/8	8	0.3150	5/16
4	0.1575	5/32	9	0.3543	23/64
5	0.1969	13/64	10	0.3937	25/64

Todas las medidas expresadas en milímetros / Todas as medidas estão em milímetros / All measurements in millimeters.

1

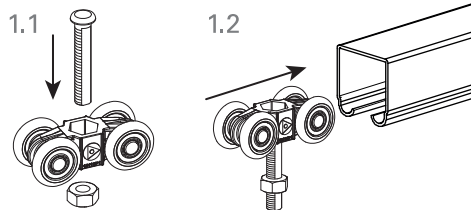

2

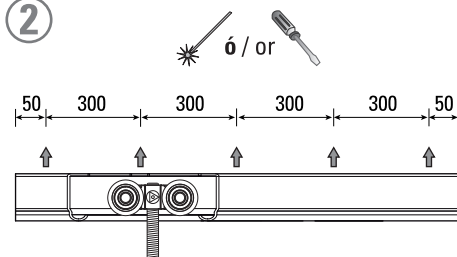

3

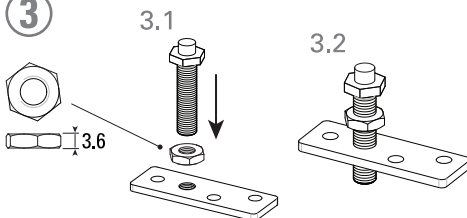

4

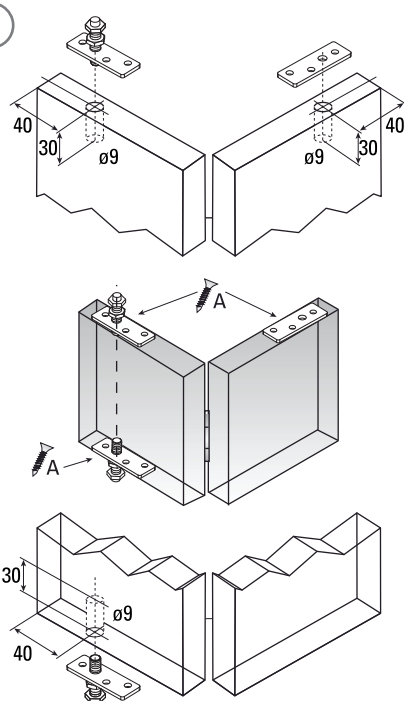

4

4.1

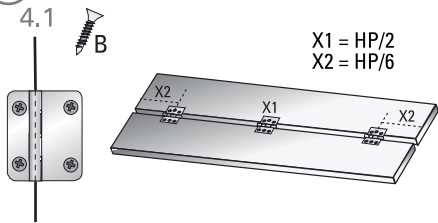

4.2

e	D
20/22/25	42
30/33	43
35/38	44
40	45

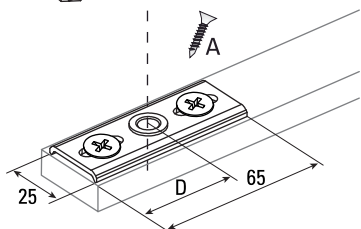
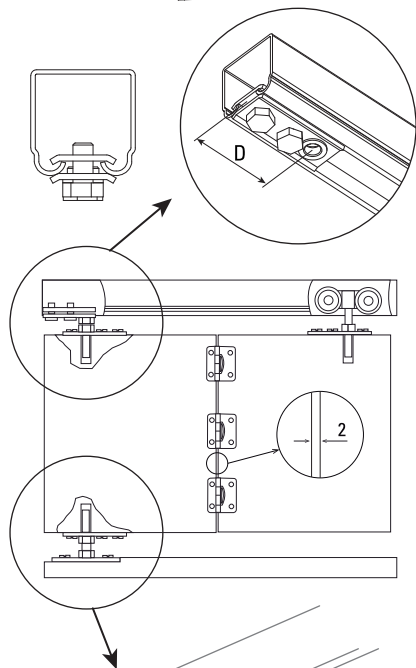
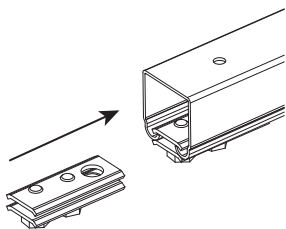

4.3

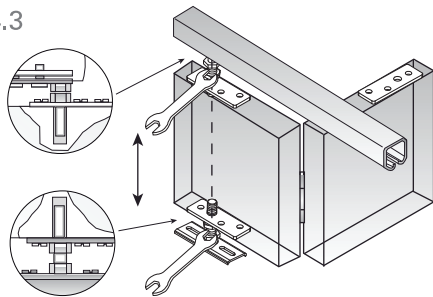

4.4

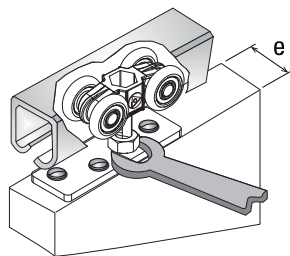

4.5

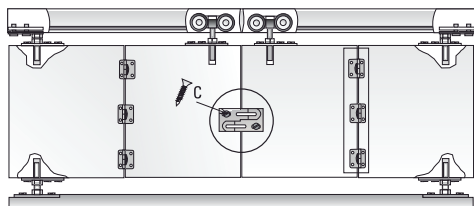

4.6

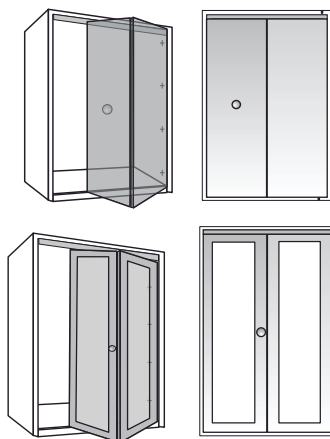

V07.11.22

0P

DUCASSE
INDUSTRIAL